

TK-3202/3206

SERVICE MANUAL



Photo is TK-3202.

CONTENTS

GENERAL	2
SYSTEM SET-UP	2
REALIGNMENT	3
DISASSEMBLY FOR REPAIR	5
CIRCUIT DESCRIPTION	8
TERMINAL FUNCTION	12
SEMICONDUCTOR DATA	12
COMPONENTS DESCRIPTION	13
PARTS LIST	14
EXPLODED VIEW	21
PACKING	22
ADJUSTMENT	24
PC BOARD	
TX-RX UNIT (X57-6890-XX)	30
SCHEMATIC DIAGRAM	34
BLOCK DIAGRAM	38
LEVEL DIAGRAM	40
KSC-31 / KNB-29N / KNB-30A / KBH-10	41
SPECIFICATIONS	BACK COVER

TK-3206 :
Does not come with antenna.
Antenna is available as an option.

TK-3202/3206

GENERAL / SYSTEM SET-UP

INTRODUCTION

SCOPE OF THIS MANUAL

This manual is intended for use by experienced technicians familiar with similar types of commercial grade communications equipment. It contains all required service information for the equipment and is current as of the publication date. Changes which may occur after publication are covered by either Service Bulletins or Manual Revisions. These are issued as required.

ORDERING REPLACEMENT PARTS

When ordering replacement parts or equipment information, the full part identification number should be included. This applies to all parts, components, kits, or chassis. If the part number is not known, include the chassis or kit number of which it is a part, and a sufficient description of the required component for proper identification.

Unit		TX-RX Unit	Frequency range	Remarks
Model & destination				
TK-3202	K,M	X57-6890-20	450~490MHz	IF1 : 38.85MHz LOC : 38.4MHz
TK-3206	M			
TK-3206	M3	X57-6890-22	400~430MHz	
TK-3202	K2, M2	X57-6890-23	470~512MHz	

PERSONAL SAFETY

The following precautions are recommended for personal safety:

- DO NOT transmit until all RF connectors are verified secure and any open connectors are properly terminated.
- SHUT OFF and DO NOT operate this equipment near electrical blasting caps or in an explosive atmosphere.
- This equipment should be serviced by a qualified technician only.

SERVICE

This radio is designed for easy servicing. Refer to the schematic diagrams, printed circuit board views, and alignment procedures contained within.

SYSTEM SET-UP

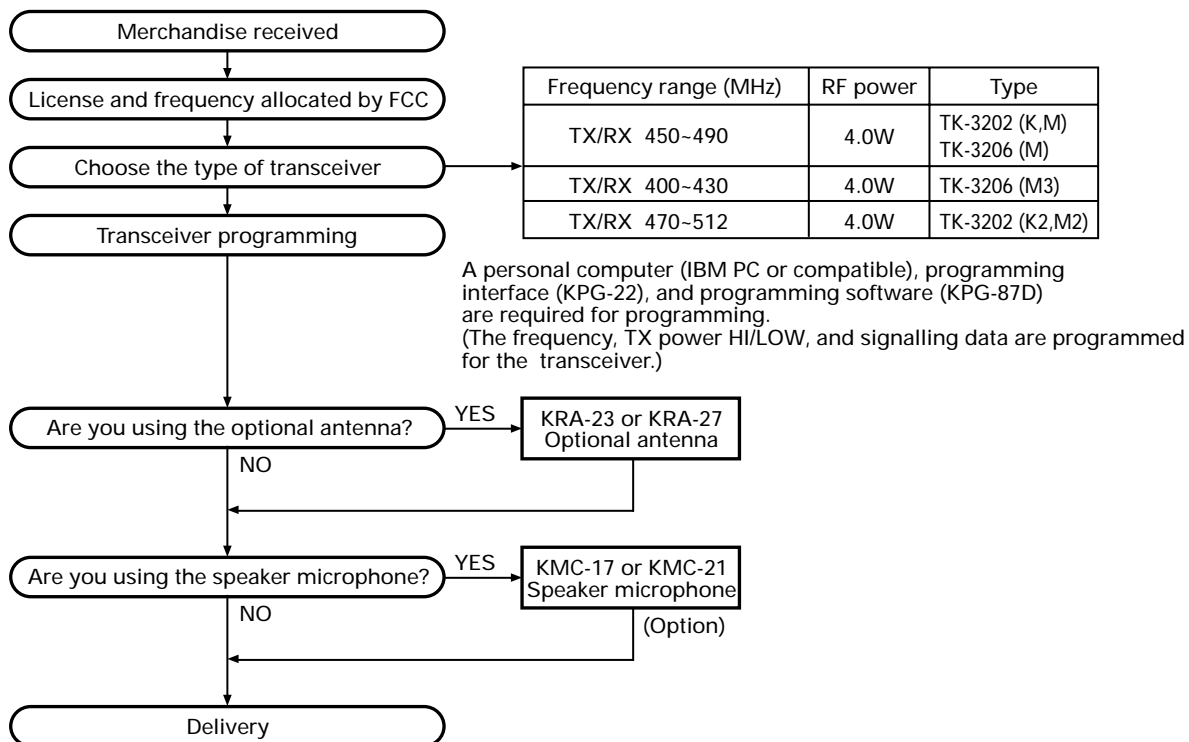

REALIGNMENT

REALIGNMENT

1. Modes

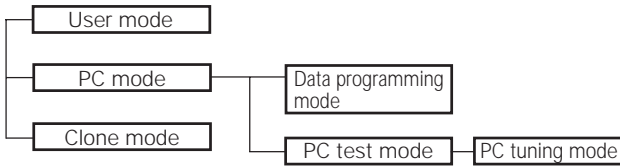

Mode	Function
User mode	For normal use.
PC mode	Used for communication between the radio and PC (IBM compatible).
Data programming mode	Used to read and write frequency data and other features to and from the radio.
PC test mode	Used to check the radio using the PC. This feature is included in the KPG-87D.
Clone mode	Used to transfer programming data from one radio to another.

2. How to Enter Each Mode

Mode	Operation
User mode	Power ON
PC mode	Received commands from PC
Clone mode	[PTT]+[Side2]+Power ON (Two seconds)

3. PC Mode

3-1. Preface

The TK-3202/3206 transceivers are programmed using a personal computer, a programming interface (KPG-22) and programming software (KPG-87D).

The programming software can be used with an IBM PC or compatible. Figure 1 shows the setup of an IBM PC for programming.

3-2. Connection procedure

1. Connect the TK-3202/3206 to the personal computer with the interface cable.
2. When the POWER is switched on, user mode can be entered immediately. When the PC sends a command, the radio enters PC mode.
When data is transmitting from the transceiver, the red LED lights.
When data is received by the transceiver, the green LED lights.

Notes:

- The data stored in the personal computer must match the model type when it is written into the EEPROM.
- Change the TK-3202/3206 to PC mode, then attach the interface cable.

3-3. KPG-22 description

(PC programming interface cable: Option)

The KPG-22 is required to interface the TK-3202/3206 with the computer. It has a circuit in its D-subconnector (25-pin) case that converts the RS-232C logic level to the TTL level.

The KPG-22 connects the SP/MIC connector of the TK-3202/3206 to the computer's RS-232C serial port.

3-4. Programming software description

KPG-87D is the programming software for TK-3202/3206 supplied on a CD-ROM. This software runs under Windows 98, ME, Windows 2000 or XP on an IBM-PC or compatible machine.

The data can be input to or read from TK-3202/3206 and edited on the screen. The programmed or edited data can be printed out. It is also possible to tune the transceiver.

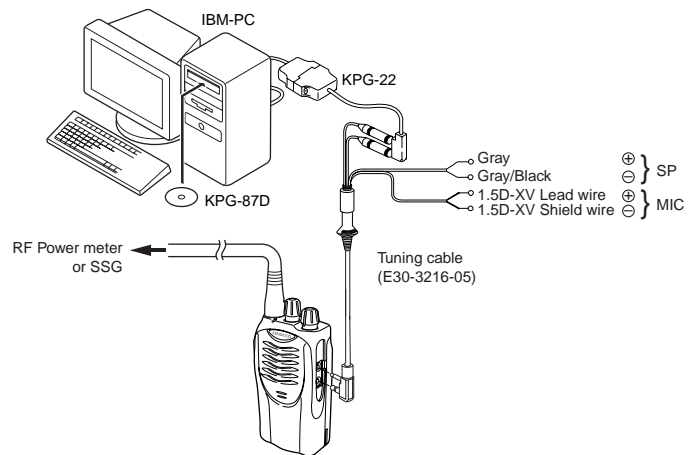

Fig. 1

4. Clone Mode

4-1. Outline

"Clone Mode" copies the transceiver data to another transceiver.

The dealer can copy the transceiver data to another transceiver even without the use of a personal computer.

4-2. Example

The transceiver can copy the programming data to one or more transceivers via RF communication.

The clone master and clone slave/s must be in Clone mode.

4-3. Operation

1. To switch the clone slave/s to Clone mode, press and hold the [PTT] and [side2] keys while turning the transceiver power ON.
2. Wait for 2 seconds. The LED will light orange and the transceiver will announce "Clone".
3. Select a channel table number using Side1(increment channel table) and Side2(decrement channel table) keys.

TK-3202/3206

REALIGNMENT

- To switch the clone master to Clone mode, press and hold the [PTT] and [side2] keys while turning the transceiver power ON.
- Wait for 2 seconds. The LED will light orange and the transceiver will announce "Clone".
- Select the same channel table number as the clone slave/s.
- Press [PTT] on the clone master to begin data transmission. When the clone slave starts to receive data, the LED will light green.
When the clone master finishes sending data, a "confirmation" tone will sound.
If data transmission fails while cloning, an "error" tone will sound from the Slave unit.
- If the cloning fails, no data will be available in the Slave unit when it is returned to User mode.
- When the cloning is successful, the Slave unit's "Scan" and "Key lock" functions will return to their default values (Scan = OFF, Key lock = OFF).

Notes:

- The dealer can clone data to two or more transceivers by repeating the above procedures.
- If the transceivers Clone Mode is configured as "Disabled", the transceiver cannot enter Clone mode.
- The table shown below will cover the frequency tables used for wireless cloning.
- Clone mode cannot be entered in battery low state.
- A unit cannot be a "Master Unit" if it is unprogrammed. If [PTT] is pressed, an "error" tone will sound.
- The language used in cloning depends on the "Model type" setting, not the FPU setting. C, C2, C5 and C6 type TK-3207 transceivers will use Chinese. Other types English.
- Once a unit is set to be the Master, it cannot be a slave after the data has been transmitted. This protects the data in the Master unit.
- Electronic interface may cause a failure in data transfer during Wireless Clone, such as when waveforms or electromagnetics are being performed at the workbench.
- Clone mode can be used ONLY by the authorized service personnel.
- The Clone mode setting must be configured as "Disable" before being delivered to the end-user.
- To clone, replace the antenna from both the master transceiver and the slave transceiver with a dummy load.
- The transmit output power is automatically set to Low in Clone mode.

Clone Frequency Table

MODEL	TK-3202		TK-3206	
Type	K,M	K2,M2	M	M3
Operating Clone Frequency Frequency (MHz) Table	450~490	470~512	450~490	400~430
1	450.000	472.000	450.000	400.000
2	452.000	474.000	452.000	401.000
3	454.000	476.000	454.000	402.000
4	456.000	478.000	456.000	403.000
5	458.000	480.000	458.000	404.000
6	460.000	482.000	460.000	405.000
7	462.000	484.000	462.000	406.000
8	464.000	486.000	464.000	407.000
9	466.000	488.000	466.000	408.000
10	468.000	490.000	468.000	409.000
11	470.000	492.000	470.000	410.000
12	472.000	494.000	472.000	411.000
13	474.000	496.000	474.000	412.000
14	476.000	498.000	476.000	413.000
15	478.000	500.000	478.000	414.000
16	480.000	502.000	480.000	415.000
17	482.000	504.000	482.000	416.000
18	484.000	506.000	484.000	417.000
19	486.000	508.000	486.000	418.000
20	488.000	510.000	488.000	419.000

DISASSEMBLY FOR REPAIR

■ Removing the case assembly from the chassis.

1. Remove the volume knob ① and channel knob ②.
2. Remove the two screws ③.
3. Lift and remove the chassis from the case assembly ④.
(Use a flat-blade screwdriver to easily lift the chassis.)

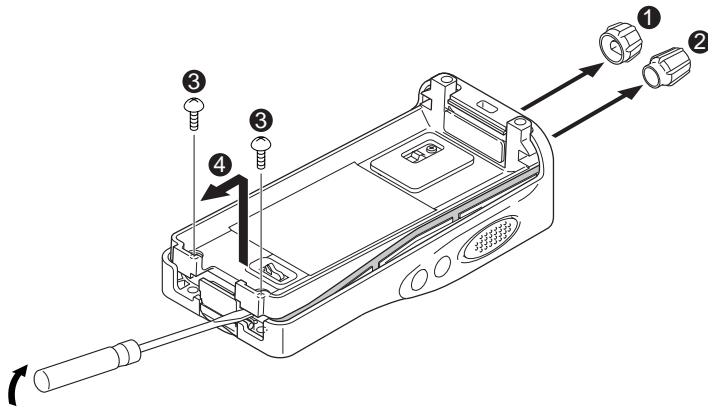

■ Removing the TX-RX unit from the chassis.

1. Remove the packing ⑤ from the SP / MIC jack of the TX-RX unit.
2. Remove the eleven screws ⑥ fixing the TX-RX unit.
3. Remove the fixing bracket ⑦ of the SP / MIC.
4. Remove the solder of the antenna terminal with a soldering iron ⑧.
5. Remove the solder of the positive terminal with a soldering iron ⑨.

Note: You can remove the TX-RX unit from the chassis without removing the solder at the positive terminal. However, in this case, you can not attach the packing (G53-1605-03) that is on the positive terminal to the chassis in assembling. So, it is advisable to remove the solder on the positive terminal first.

6. Remove the FPC from the flat cable connector ⑩.
7. Lift and remove the TX-RX unit from the chassis ⑪.

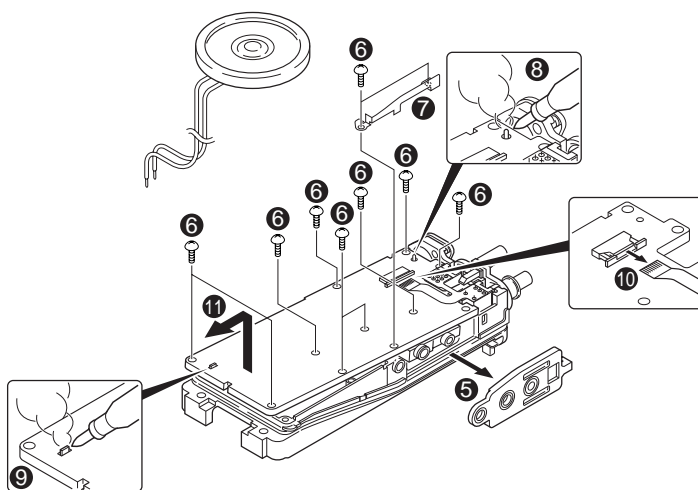

■ Removing the battery release lever from the case assembly.

1. Press the upper part of the lever toward the inside of the case assembly. One side of the shaft will be removed ①.
2. Lift and remove the battery release lever from the case assembly ②.

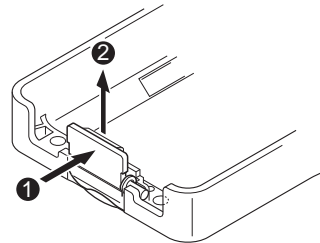

■ Attaching the battery release lever to the case assembly.

1. Insert one side of the shaft into the hole at the lever fitting section on the case assembly ①.

Caution : The thin spring (G01-4543-04) should be positioned above the two tabs of the lever.

2. Tilt the battery release lever slightly forward ②, so that the thick spring (G01-4542-04) is positioned below the case surface.
3. With the thick spring positioned below the case surface, attach the other side of the shaft to the case assembly by pressing the battery release lever ③ until it snaps into place ④.

Caution : Be careful not to tilt the battery release lever too forward.

If the battery release lever is pushed in this state where the two tabs come below the case surface, there is a possibility of damaging the two tabs.

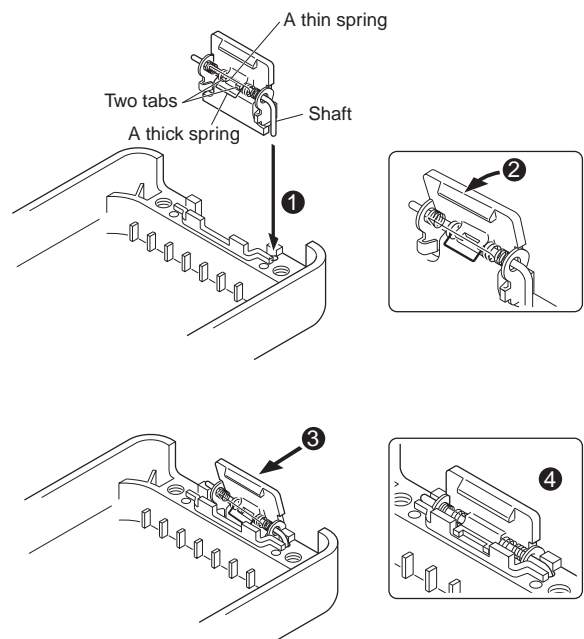

TK-3202/3206

DISASSEMBLY FOR REPAIR

■ Assembling the battery release lever

1. Place the lever ② onto the stopper ①.
2. Place the thick spring ③ onto the lever.
3. Hook the right and left ends of the thin spring ④ onto the tabs of the stopper, then place the thin spring onto the lever ⑤.
4. Slide the shaft through the hole of the stopper and lever ⑥.

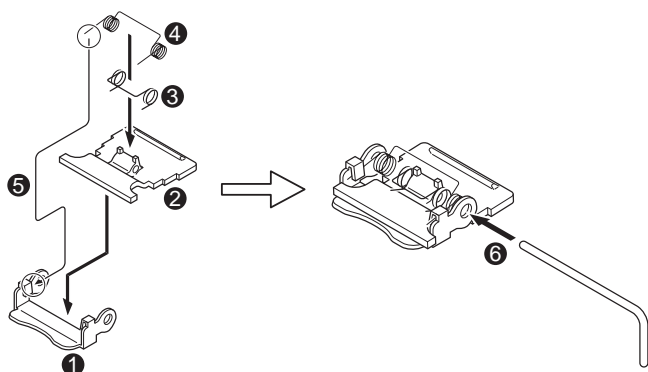

2. Mounting the chassis to the case assembly.

1. Confirm that the waterproof packing attached to the circumference of the chassis is securely inserted in the groove of the chassis ①.
2. Twist the speaker wires twice, then attach the speaker to the speaker recess of the case assembly ②. Make sure the speaker is securely inserted.

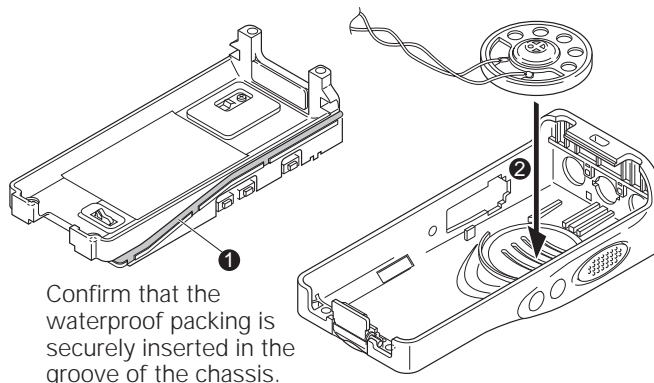

Confirm that the waterproof packing is securely inserted in the groove of the chassis.

■ Cautions for assembly

1. Attaching the positive terminal to the chassis.

Always attach the positive terminal to the chassis, using the following procedures, before mounting the TX-RX unit onto the chassis.

1. Remove the holder assembly ② from the packing ① of the positive terminal.
2. Mount the packing of the positive terminal into the chassis hole ③.
3. Mount the holder assembly into the packing of the positive terminal ④.

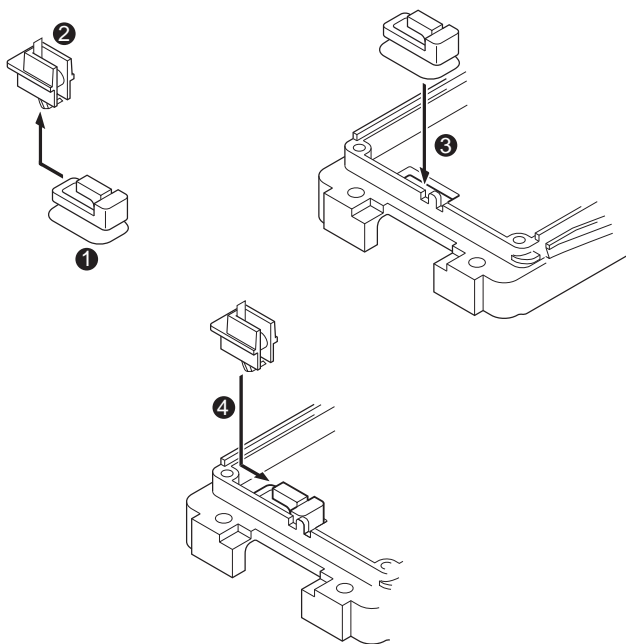

3. Insert the upper part of the chassis into the case assembly ③.

Caution: Take care that the speaker lead wire is not caught by the microphone element.

4. Press the chassis ④ and the case assembly together to attach them.

Caution: If the packing of the SP / MIC does not come to the correct position after attaching the chassis to the case assembly, reposition the packing with your fingers.

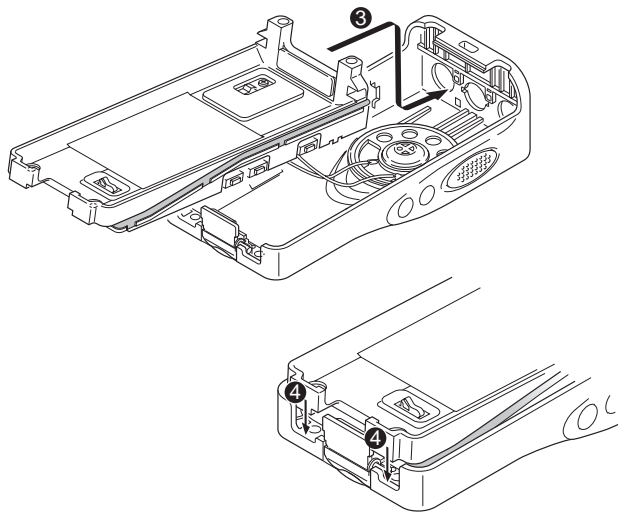

DISASSEMBLY FOR REPAIR

3. Attaching the antenna receptacle to the chassis.

Screw the antenna receptacle to the chassis in the order shown in the drawing so that the antenna receptacle comes to the center of the case hole.

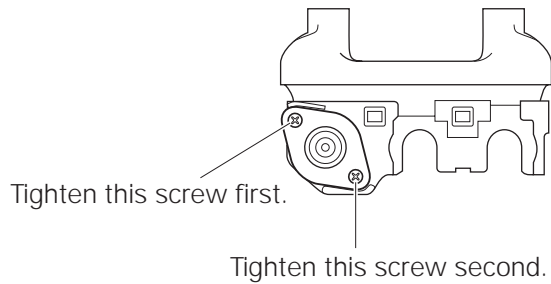

5. Screw sequence for mounting the TX-RX unit to the chassis.

Attach the TX-RX unit to the chassis using the screws in the order shown in the drawing below.

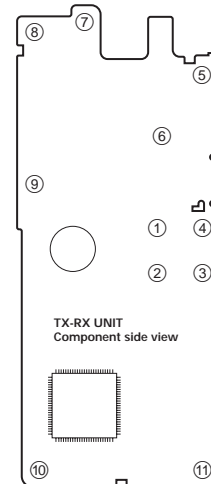

4. The nuts of the volume knob and channel knob

Note that the shapes, colors and heights of nuts of the volume knob and channel knob are different from one another. (The nut of volume knob is silver, and the nut of channel knob is gold)

Use the following jig when removing the nuts of the volume knob and channel knob.

- Jig (Part No. : W05-1012-00)

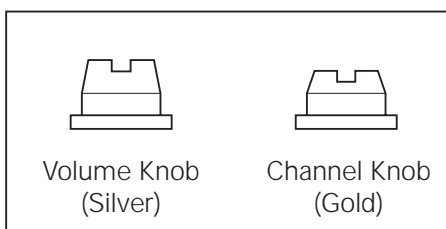

TK-3202/3206

CIRCUIT DESCRIPTION

1. Frequency Configuration

The receiver utilizes double conversion. The first IF is 38.85 MHz and the second IF is 450 kHz. The first local oscillator signal is supplied from the PLL circuit.

The PLL circuit in the transmitter generates the necessary frequencies. Fig. 1 shows the frequencies.

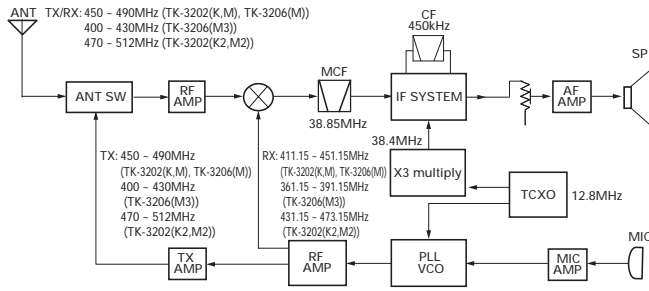

Fig. 1 Frequency configuration

2. Receiver

The frequency configuration of the receiver is shown in Fig. 2.

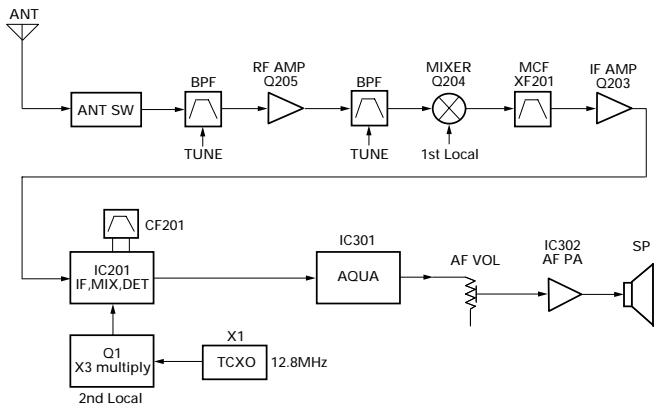

Fig. 2 Receiver section

1) Front End (RF AMP)

The signal coming from the antenna passes through the transmit/receive switching diode circuit, (D103,D104,D106 and D122) passes through a BPF (L229 and L228), and is amplified by the RF amplifier (Q205).

The resulting signal passes through a BPF (L214,L212 and L211) and goes to the mixer. These BPFs are adjusted by variable capacitors (D203,D204,D205,D206 and D210). The input voltage to the variable capacitor is regulated by voltage output from the microprocessor (IC405).

2) First Mixer

The signal from the front end is mixed with the first local oscillator signal generated in the PLL circuit by Q1 to produce a first IF frequency of 38.85 MHz.

The resulting signal passes through the XF201 MCF to cut the adjacent spurious and provide the optimum characteristics, such as adjacent frequency selectivity.

3) IF Amplifier Circuit

The first IF signal is passed through a four-pole monolithic crystal filter (XF201) to remove the adjacent channel signal. The filtered first IF signal is amplified by the first IF amplifier (Q203) and then applied to the IF system IC (IC201). The IF system IC provides a second mixer, second local oscillator, limiting amplifier, quadrature detector and RSSI (Received Signal Strength Indicator). The second mixer mixes the first IF signal with the 38.4MHz of the second local oscillator output (TCXO X1) and produces the second IF signal of 450kHz.

The second IF signal is passed through the ceramic filter (CF201) to remove the adjacent channel signal. The filtered second IF signal is amplified by the limiting amplifier and demodulated by the quadrature detector with the ceramic discriminator (CD201). The demodulated signal is routed to the audio circuit.

4) Wide/Narrow Switching Circuit

Narrow and Wide settings can be made for each channel by switching the demodulation level.

The WIDE (low level) and NARROW (high level) data is output from IC405, pin 45.

When a WIDE (low level) data is received, Q202 turn on. When a NARROW (high level) data is received, Q202 turn off.

Q202 turns off/on with the Wide/Narrow data and the IC201 detector output level is switched to maintain a constant output level during wide or narrow signals.

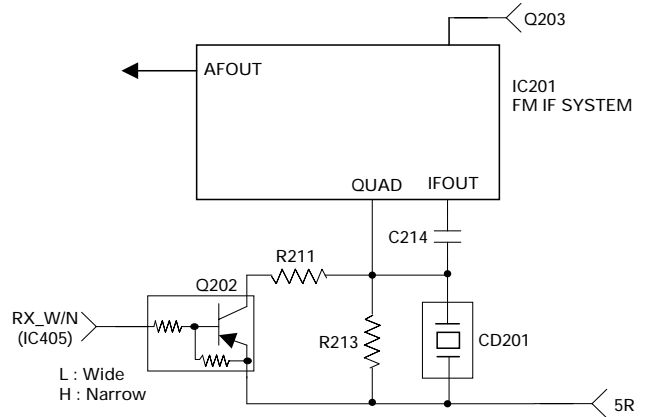

Fig. 3 Wide/Narrow switching circuit

5) Audio Amplifier Circuit

The demodulated signal from IC201 goes to AF amplifier through IC301.

The signal then goes through an AF volume control, and is routed to an audio power amplifier (IC302) where it is amplified and output to the speaker.

CIRCUIT DESCRIPTION

6) Squelch

Part of the AF signal from the IC enters the FM IC (IC201) again, and the noise component is amplified and rectified by a filter and an amplifier to produce a DC voltage corresponding to the noise level.

The DC signal from the FM IC goes to the analog port of the microprocessor (IC405). IC405 determines whether to output sounds from the speaker by checking whether the input voltage is higher or lower than the preset value.

To output sounds from the speaker, IC405 sends a high signal to the SP MUTE line and turns IC302 on through Q303, Q304, Q305, Q306 and Q316. (See Fig. 4)

7) Receive Signalling

(1) QT/DQT

The output signal from FM IC (IC201) enters the microprocessor (IC405) through IC301. IC405 determines whether the QT or DQT matches the preset value, and controls the SP MUTE and the speaker output sounds according to the squelch results.

(2) MSK (Fleet Sync)

The MSK input signal from the FM IC goes to pin 31 of IC 301. The signal is demodulated by MSK demodulator in IC 301. The demodulated data goes to the CPU for processing.

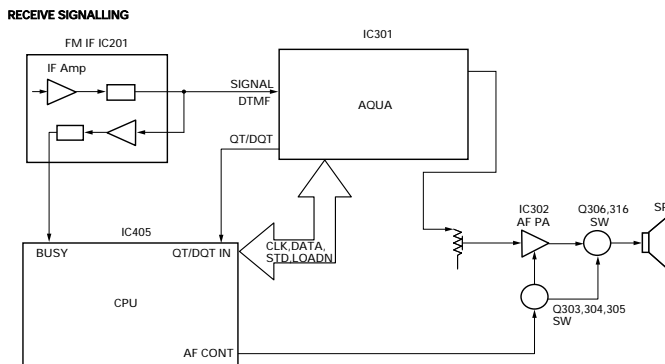

Fig. 4 AF amplifier and squelch

(3) DTMF

The DTMF input signal from the FM IC (IC201) goes to IC301, the DTMF decoder. The decoded information is then processed by the CPU.

3. PLL Frequency Synthesizer

The PLL circuit generates the first local oscillator signal for reception and the RF signal for transmission.

1) PLL

The frequency step of the PLL circuit is 5 or 6.25kHz.

A 12.8MHz reference oscillator signal is divided at IC1 by a fixed counter to produce oscillator (VCO) output signal which is buffer amplified by Q2 then divided in IC1 by a programmable counter. The divided signal is compared in

phase with the 5 or 6.25kHz reference signal from the phase comparator in IC1. The output signal from the phase comparator is filtered through a low-pass filter and passed to the VCO to control the oscillator frequency. (See Fig. 5)

2) VCO

The operating frequency is generated by Q4 in transmit mode and Q3 in receive mode. The oscillator frequency is controlled by applying the VCO control voltage, obtained from the phase comparator, to the varactor diodes (D4 and D7 in transmit mode and D5 and D9 in receive mode). The RX pin is set high in receive mode causing Q5 turn on.

The TX pin is set high in transmit mode. The outputs from Q3 and Q4 are amplified by Q6 and sent to the RF amplifiers.

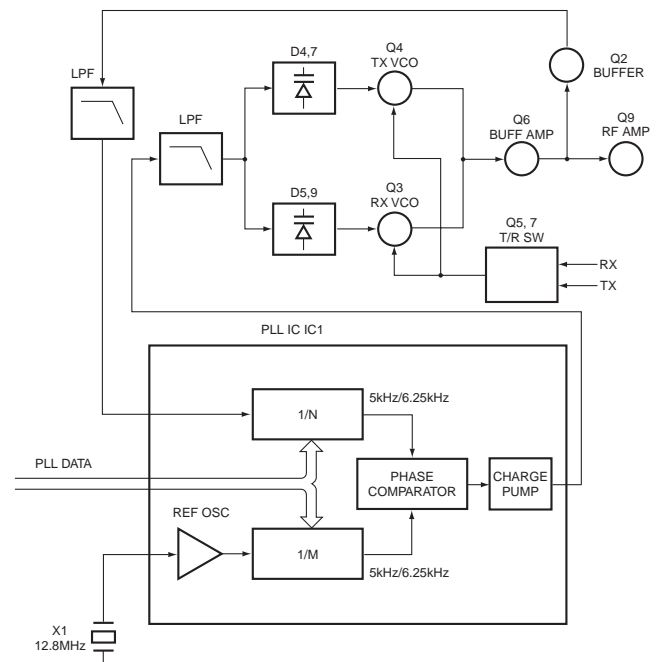

Fig. 5 PLL circuit

3) Unlock Detector

If a pulse signal appears at the LD pin of IC1, an unlock condition occurs, and the DC voltage obtained from C4, R5, and D1 causes the voltage applied to the microprocessor to go low. When the microprocessor detects this condition, the transmitter is disabled, ignoring the push-to-talk switch input signal.

CIRCUIT DESCRIPTION

4. Transmitter System

1) Microphone Amplifier

The signal from the microphone passes through IC301. When encoding DTMF, it is turned OFF for muting the microphone input signal by IC301. The signal passes through the Audio processor (IC301) for the maximum deviation adjustment, and goes to the VCO modulation input.

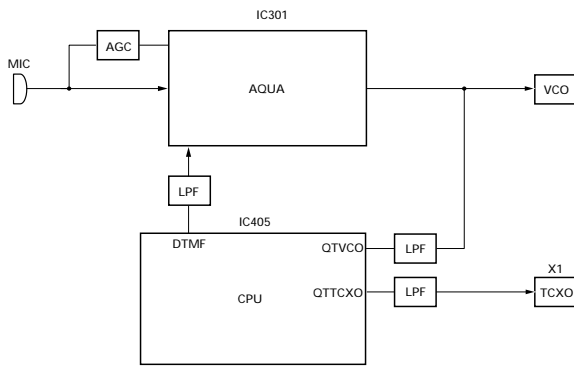

Fig. 6 Microphone amplifier

2) Drive and Final Amplifier

The signal from the T/R switch (D101 is on) is amplified by the pre-drive (Q101) and drive amplifier (Q102) to 50mW. The output of the drive amplifier is amplified by the RF power amplifier (Q103) to 4.0W (1W when the power is low). The RF power amplifier consists of two MOS FET stages. The output of the RF power amplifier is then passed through the harmonic filter (LPF) and antenna switch (D103 and D122) and applied to the antenna terminal.

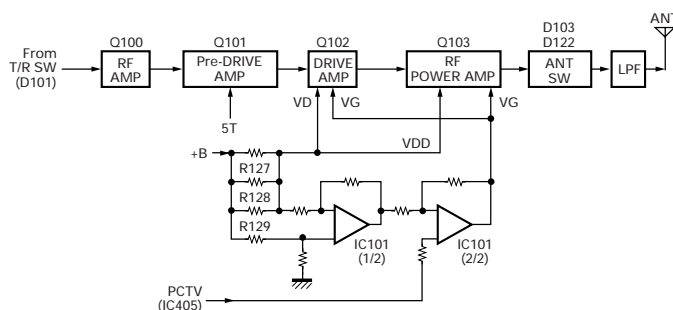

Fig. 7 Drive and final amplifier and APC circuit

3) APC Circuit

The APC circuit always monitors the current flowing through the RF power amplifier (Q103) and keeps a constant current. The voltage drop at R127, R128 and R129 is caused by the current flowing through the RF power amplifier and this voltage is applied to the differential amplifier IC101(1/2). IC101(2/2) compares the output voltage of IC101(1/2) with the reference voltage from IC405. The output of IC101(2/2) controls the VG of the RF power amplifier, Drive amplifier

and Pre-Drive amplifier to make both voltages the same. The change of power high/low is carried out by the change of the reference voltage.

4) Encode Signalling

(1) QT/DQT

QT, DQT data of the QTTXCO Line is output from pin 28 of the CPU. The signal passes through a low-pass CR filter and goes to the TCXO(X1).

The QT, DQT data of the QTVCO Line is output from pin 24 of the CPU. The signal passes through a low pass CR filter, mixes with the audio signal, and goes to the VCO modulation input. TX deviation is adjusted by the CPU.

(2) DTMF

High-speed data is output from pin 2 of the CPU. The signal passes through a low-pass CR filter, and provides a TX and SP out tone, and is then applied to the audio processor (IC301). The signal is mixed with the audio signal and goes to the VCO.

TX deviation is adjusted by the CPU.

(3) MSK (Fleet Sync)

Fleet Sync utilizes 1200bps and 2400bps MSK signal is output from pin 6 of IC301. And is routed to the VCO. When encoding MSK, the microphone input signal is muted.

5. Power Supply

There are four 5V power supplies for the microprocessor: 5M, 5C, 5R, and 5T. 5M for microprocessor is always output while the power is on. 5M is always output, but turns off when the power is turned off to prevent malfunction of the microprocessor.

5C is a common 5V and is output when SAVE is not set to OFF.

5R is 5V for reception and output during reception.

5T is 5V for transmission and output during transmission.

6. Control Circuit

The control circuit consists of a microprocessor (IC405) and its peripheral circuits. It controls the TX-RX unit. IC405 mainly performs the following:

- (1) Switching between transmission and reception by the PTT signal input.
- (2) Reading system, group, frequency, and program data from the memory circuit.
- (3) Sending frequency program data to the PLL.
- (4) Controlling squelch on/off by the DC voltage from the squelch circuit.
- (5) Controlling the audio mute circuit by the decode data input.
- (6) Transmitting tone and encode data.

1) Frequency Shift Circuit

The microprocessor (IC405) operates at a clock of 7.3728MHz. This oscillator has a circuit that shifts the frequency by BEAT SHIFT SW (Q407, Q408).

CIRCUIT DESCRIPTION

A beat sound may be able to be evaded from generation if "Beat Shift" is set to ON when it is generated in the internal spurious transmission modulated sound of a transceiver.

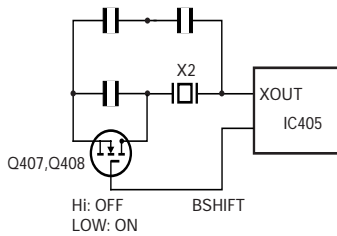

Fig. 8 Frequency shift circuit

2) Memory Circuit

Memory circuit consists of the CPU (IC405) and an EEPROM (IC406). An EEPROM has a capacity of 64k bits that contains the transceiver control program for the CPU and data such as transceiver channels and operating features.

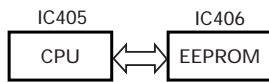

Fig. 9 Memory circuit

3) Low Battery Warning

The battery voltage is checked using by the microprocessor. The transceiver generates a warning tone when it falls below the warning voltage shown in the table.

(1) The red LED blinks when the battery voltage falls below the voltage (1) shown in the table during transmission.

Note:

The transceiver checks the battery voltage during reception even when, in the FPU, the Battery Warning status function is set to "On TX" (default setting).

However, the LED does not blink during reception. During transmission, the LED blinks to generate the warning tone of a low battery voltage.

(2) The transceiver immediately stops transmission when the battery voltage falls below the voltage (2) shown in the table. A message tone beeps while the PTT switch is released.

	Ni-Cd Battery	Ni-MH Battery
(1)	6.2[V]	6.2[V]
(2)	5.9[V]	5.9[V]

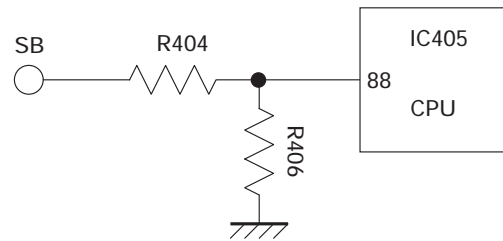

Fig. 10 Low battery warning

7. Control System

Keys and channel selector circuit.

The signal from keys and channel selector input to microprocessor directly as shown in fig. 11.

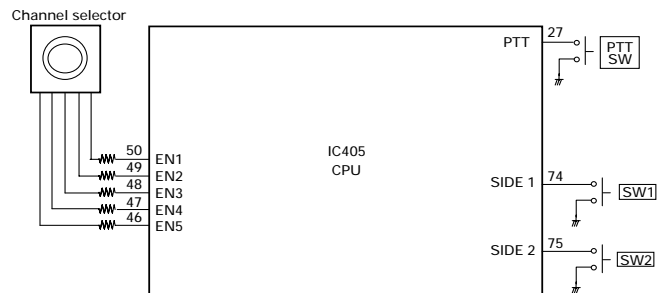

Fig. 11 Control system

TK-3202/3206

TERMINAL FUNCTION / SEMICONDUCTOR DATA

TERMINAL FUNCTION

■ CN401

Pin No.	Name	I/O	Function
1	B	I	B (Battery Voltage)
2	SB	O	Switched B
3	SP1	I	Audio input
4	SP2	O	Audio output
5	GND	-	GND
6	EN1	I	Encoder pulse input

Pin No.	Name	I/O	Function
7	EN2	I	Encoder pulse input
8	GND	-	GND
9	EN3	I	Encoder pulse input
10	EN4	I	Encoder pulse input
11	EN5	I	Encoder pulse input

SEMICONDUCTOR DATA

Microprocessor : 30622MAA-B89GP (TX-RX UNIT : IC405)

■ Pin function

Pin No.	Port Name	I/O	Function
1	PCTV	O	APC/BPF control data output
2	DTMF	O	DTMF/ Beep output
3	NC	-	NC
4	EEPDAT	I/O	EEPROM data input/output
5	EEPCLK	O	EEPROM clock output
6	BYTE	-	GND
7	GND	-	GND
8	BSHIFT	O	Beat shift switch
9	NC	-	NC
10	RESET	I	CPU reset
11	XOUT	O	CPU clock (7.3728MHz)
12	VSS	-	GND
13	XIN	I	CPU clock (7.3728MHz)
14-15	VCC	-	+5V
16	INT	I	Battery voltage monitor input
17	TCLK/DTRDO	I	Base band IC data input
18	RDF/FD	I	Base band IC data input
19	SCLK	O	Base band IC clock output
20	D I/O	I/O	Base band IC data input / output
21	TDATA/DTRCLK	O	Base band IC data output
22	DIR	O	Base band IC data output
23	STD	I	Base band IC data input
24	QT VCO	O	QT/DQT output
25	DTRLOADN	O	Base band IC data output
26	1/2 OSC	O	3.6864 MHz (7.3728 MHz/2)
27	PTT	I	PTT switch input
28	QT TCXO	O	QT/DQT output
29	TXD	O	Serial data (FPU/FLASH)
30	RXD	I	Serial data (FPU/FLASH)
31	GND	-	GND
32	APCSW	O	APC switch
33-34	NC	-	NC
35	DCSW	O	APC voltage discharge switch
36	TX_W/N	O	TX Wide/Narrow switch
37	RX_SW	O	RX VCO switch
38	TX_SW	O	TX VCO switch
39	GND	-	GND
40	PLL_UL	I	PLL unlock detect input
41	PLL_STB	O	PLL strobe output
42	PLL_DAT	O	PLL data output
43	PLL_CLK	O	PLL clock output

Pin No.	Port Name	I/O	Function
44	VCC	-	+5V
45	RX_W/N	O	RX Wide/Narrow switch
46	EN5	I	Channel selector input
47	EN4	I	Channel selector input
48	EN3	I	Channel selector input
49	EN2	I	Channel selector input
50	EN1	I	Channel selector input
51	OPTDET	I	Headset input detect
52	AF_CONT	O	Speaker mute
53-59	NC	-	NC
60	VCC	-	+5V
61	NC	-	NC
62	VSS	-	GND
63-64	GND	-	GND
65-71	NC	-	NC
72	LEDTX	O	Red LED lights control output
73	LEDRX	O	Green LED lights control output
74	PF1	I	SIDE1 key input
75	PF2	I	SIDE2 key input
76	SIM1	-	GND
77	SIM2	-	GND
78-79	NC	-	NC
80	5T_C	O	5T control output
81	5R_C	O	5R control output
82	5C_C	O	5C control output
83-87	NC	-	NC
88	BATT	I	Battery voltage input
89	RSSI	I	Received Signal Strength Indicator input
90	BUSY	I	Busy level input
91	VOX	I	VOX level input
92	QT/DQT_IN	I	QT/DQT input
93	TH_DET	I	Thermistor input
94	AVSS	-	GND
95	NC	-	NC
96	VREF	-	+5V
97	AVCC	-	+5V
98	NC	-	NC
99	MIC_MUTE	O	MIC mute
100	NC	-	NC

COMPONENTS DESCRIPTION

TX-RX UNIT (X57-6890-XX)

Ref. No.	Use/Function	Operation/Condition
IC1	IC	PLL system
IC101	IC	Comparator (APC)
IC201	IC	FM IF system
IC301	IC	Audio processor
IC302	IC	AF AMP
IC401	IC	Voltage regulator/ 5V
IC402	IC	Voltage regulator/ 5V
IC403	IC	Voltage detector / Reset
IC404	IC	Voltage detector / INT
IC405	IC	Microprocessor
IC406	IC	EEPROM
Q1	Transistor	Tripler
Q2	Transistor	PLL IC f_in AMP
Q3	FET	VCO / RX
Q4	FET	VCO / TX
Q5	Transistor	DC switch / TX VCO
Q6	FET	RF Buffer AMP
Q7	Transistor	DC switch / RX VCO
Q8	Transistor	Ripple filter
Q9	Transistor	RF AMP
Q100	Transistor	RF AMP
Q101	FET	RF AMP
Q102	FET	TX Drive AMP
Q103	FET	TX Final AMP
Q104	Transistor	APC switch
Q105	FET	APC switch
Q107	Transistor	APC switch
Q108	FET	APC switch
Q109	Transistor	APC switch
Q202	Transistor	W/N switch / RX
Q203	Transistor	IF AMP
Q204	FET	Mixer
Q205	FET	RF AMP
Q301	Transistor	W/N switch / TX
Q302	Transistor	MIC AGC
Q303	Transistor	DC switch / SP Mute
Q304	Transistor	DC switch
Q305	Transistor	DC switch / SP Mute
Q306	FET	SP Mute switch
Q316	FET	SP Mute switch
Q401	Transistor	LED switch / Red
Q402	Transistor	LED switch / Green
Q403	FET	5T switch
Q404	FET	5R switch
Q405	Transistor	5C switch
Q407	FET	Beat Shift switch
Q408	FET	Beat Shift switch
D1	Diode	Ripple Filter
D2	Variable capacitance diode	Frequency control / TX VCO
D3	Variable capacitance diode	Frequency control / RX VCO

Ref. No.	Use/Function	Operation/Condition
D4	Variable capacitance diode	Frequency control / TX VCO
D5	Variable capacitance diode	Frequency control / RX VCO
D6	Variable capacitance diode	Frequency control / TX VCO
D7	Variable capacitance diode	Frequency control / TX VCO
D8	Variable capacitance diode	Frequency control / RX VCO
D9	Variable capacitance diode	Frequency control / RX VCO
D10	Variable capacitance diode	Modulator
D11	Diode	Current steering
D101	Diode	TX/RX RF switch
D102	Zener diode	APC protect
D103	Diode	ANT switch
D104	Diode	ANT switch
D106	Diode	ANT switch
D122	Diode	ANT switch
D202	Diode	TX/RX RF switch
D203	Variable capacitance diode	RF BPF tuning
D204	Variable capacitance diode	RF BPF tuning
D205	Variable capacitance diode	RF BPF tuning
D206	Variable capacitance diode	RF BPF tuning
D210	Variable capacitance diode	RF BPF tuning
D301	Diode	Detector
D302	Diode	Detector
D303	Diode	Isolation
D401	Diode	5V Protection
D402	Diode	Reverse Protection
D403	LED	LED/ Red
D404	LED	LED/ Green

ADDITIONAL PCB

Ref. No.	Use/Function	Operation/Condition
Q901	FET	W/N Switch/ TX

TK-3202/3206

PARTS LIST

* New Parts. Δ indicates safety critical components.
 Parts without **Parts No.** are not supplied.
 Les articles non mentionnés dans le **Parts No.** ne sont pas fournis.
 Teile ohne **Parts No.** werden nicht geliefert.

L: Scandinavia K: USA P: Canada
 Y: PX (Far East, Hawaii) T: England E: Europe
 Y: AAFES (Europe) X: Australia M: Other Areas

TK-3202/3206 (Y50-5900-XX) TX-RX UNIT (X57-6890-XX)

Ref. No.	Address	New parts	Parts No.	Description	Destination
TK-3202/3206					
1	1A	*	A02-3851-23	CABINET ASSY(16CH)	BM,BM3
1	1A	*	A02-3852-23	CABINET ASSY(8CH)	AK,AK2
1	1A	*	A02-3852-23	CABINET ASSY(8CH)	AM,AM2
2	1A	*	A02-3858-13	CABINET	
3	3A	*	A10-4078-01	CHASSIS	
4	1B	*	A21-1644-13	DRESSING PANEL(16CH)	BM,BM3
4	1B	*	A21-1645-13	DRESSING PANEL(8CH)	AK,AK2
4	1B	*	A21-1645-13	DRESSING PANEL(8CH)	AM,AM2
6	2C,2E	*	B09-0680-03	CAP(SP/MIC) ACCESSORY	
7	2B	*	B11-1817-04	ILLUMINATION GUIDE	
8	1B	*	B43-1156-04	BADGE	
9	1C	*	B62-1762-00	INSTRUCTION MANUAL	AK,AK2
9	1C	*	B62-1762-00	INSTRUCTION MANUAL	AM,AM2
10	1E	*	B62-1763-00	INSTRUCTION MANUAL	BM,BM3
11	1A	*	D10-0649-03	LEVER	
12	1A	*	D21-0863-04	SHAFT	
13	1A	*	D32-0441-03	STOPPER	
14	2A	*	E04-0451-05	RF COAXIAL RECEPTACLE(SMA)	
15	3B	*	E23-1253-04	TERMINAL(BATT-)	
16	2B	*	E37-0794-05	PROCESSED LEAD WIRE(SP+)	
17	2B	*	E37-0803-05	PROCESSED LEAD WIRE(SP-)	
18	3A	*	F20-3353-14	INSULATING SHEET(CHASSIS BATT+)	
19	2A	*	G01-4542-04	COIL SPRING(LEVER)	
20	1A	*	G01-4543-04	COIL SPRING(STOPPER)	
21	2B	*	G10-1330-04	FIBROUS SHEET(IC302:AUDIO IC)	
22	3A	*	G11-2622-04	SHEET	
23	3A	*	G11-4283-04	RUBBER SHEET(Q103:FINAL FET)	
24	2A	*	G11-4313-04	SHEET(MIC ELEMENT)	
25	3B	*	G11-4318-04	SHEET	
26	3A	*	G11-4320-14	SHEET	
27	2B,3B	*	G11-4322-04	SHEET	
28	2A	*	G11-4323-04	SHEET	
29	3B	*	G13-2009-04	CUSHION(TERMINAL BATT-)	
30	3A	*	G13-2033-04	CUSHION(TERMINAL BATT-)	
31	3B	*	G13-2034-14	CUSHION(CHASSIS)	
32	2B	*	G13-2037-04	CUSHION(CHASSIS VOL/CH)	
33	3A	*	G13-2038-04	CUSHION(CHASSIS-CERAMIC FILTER)	
34	2A	*	G13-2039-04	CUSHION(PCB-CERAMIC FILTER)	
35	3A	*	G53-1604-03	PACKING(CHASSIS)	
36	3A	*	G53-1605-03	PACKING(TERMINAL BATT+)	
37	2B	*	G53-1606-03	PACKING(VOL/CH/LED)	
38	1B	*	G53-1607-03	PACKING(SP/MIC)	
39	2B	*	G53-1608-03	PACKING(SP)	
40	2A	*	G53-1609-14	PACKING(MIC ELEMENT)	
41	2B	*	G53-1610-04	PACKING(SMA)	
43	2C,2F	*	H12-3158-05	PACKING FIXTURE	
44	1D	*	H13-2109-03	CARTON BOARD	AK,AK2
44	1D	*	H13-2109-03	CARTON BOARD	AM,AM2
45	1C,1E	*	H25-0085-04	PROTECTION BAG (100/200/0.07)	
46	3D	*	H52-2056-02	ITEM CARTON CASE	AK,AK2
46	3D	*	H52-2056-02	ITEM CARTON CASE	AM,AM2

Ref. No.	Address	New parts	Parts No.	Description	Destination
47	3F	*	H52-2057-02	ITEM CARTON CASE	BM,BM3
48	2C,2F	*	J19-5472-03	HOLDER(SP/MIC) ACCESSORY	
49	2A	*	J19-5473-03	HOLDER ASSY(TERMINAL BATT+)	
50	2B	*	J21-8477-04	HARDWARE FIXTURE(VOL/CH)	
51	2B	*	J21-8478-04	HARDWARE FIXTURE(SP/MIC)	
52	2C,2F	*	J29-0713-05	BELT CLIP ACCESSORY	
54	2B	*	J82-0092-05	FPC	
56	1A	*	K29-9307-03	BUTTON KNOB(SIDE1/SIDE2)	
57	1A	*	K29-9308-03	BUTTON KNOB(PTT)	
58	1B	*	K29-9309-03	KNOB(VOL)	
59	1B	*	K29-9318-03	KNOB(CH)	
A	2B	*	N14-0808-04	CIRCULAR NUT(CH KNOB)	
B	2B	*	N14-0812-04	CIRCULAR NUT(VOL KNOB)	
C	2A,2B	*	N30-2604-46	PAN HEAD MACHINE SCREW(SMA)	
D	3A	*	N30-2606-46	PAN HEAD MACHINE SCREW(CHASSIS)	
E	2A,2B,3B	*	N83-2005-46	PAN HEAD TAPTITE SCREW(PCB)	
60	1C,2F	*	N99-2043-05	SCREW SET ACCESSORY	
61	2B	*	R31-0653-05	VARIABLE RESISTOR(POWER SW/VOL)	
62	2B	*	S60-0427-05	ROTARY SWITCH(16CH)	BM,BM3
62	2B	*	S60-0428-15	ROTARY SWITCH(8CH)	AK,AK2
62	2B	*	S60-0428-15	ROTARY SWITCH(8CH)	AM,AM2
63	1B	*	T07-0369-05	SPEAKER	
64	1C	*	T90-1039-05	WHIP ANTENNA ACCESSORY	AK,AM
64	1C	*	T90-1040-05	WHIP ANTENNA ACCESSORY	AK2,AM2
65	2D	*	W08-0969-05	CHARGER ACCESSORY	AK,AK2
65	2D	*	W08-0969-05	CHARGER ACCESSORY	AM,AM2
66	1D	*	W08-0970-05	AC ADAPTER(AC120V) ACCESSORY	AK,AK2
66	1D	*	W08-0971-05	AC ADAPTER(AC230V) ACCESSORY	AM,AM2

TX-RX UNIT (X57-6890-XX) -20 :TK-3202 (K,M) TK-3206 (M) -22 :TK-3206 (M3) -23 :TK-3202 (K2,M2)

D403			B30-2156-05	LED(RED)	
D404			B30-2157-05	LED(YELLOW)	
C1			CK73HB1H332K	CHIP C 3300PF	K
C2			CK73HB1C682K	CHIP C 6800PF	K
C3			CK73GB1A105K	CHIP C 1.0UF	K
C4			CK73HB1C103K	CHIP C 0.010UF	K
C5			CK73HB1H102K	CHIP C 1000PF	K
C6			CK73HB1A104K	CHIP C 0.10UF	K
C7 ,8			CC73HCH1H101J	CHIP C 100PF	J
C9			CC73HCH1H100D	CHIP C 10PF	D
C10			C92-0713-05	CHIP-TAN 10UF	6.3WV
C11			CC73HCH1H101J	CHIP C 100PF	J
C12			CK73HB1H102K	CHIP C 1000PF	K
C13			CK73HB1A104K	CHIP C 0.10UF	K
C14			CK73HB1C103K	CHIP C 0.010UF	K
C15			CC73HCH1H100D	CHIP C 10PF	D
C16			CK73HB1H102K	CHIP C 1000PF	K
C17			CC73HCH1H470J	CHIP C 47PF	J
C18			CC73HCH1H180J	CHIP C 18PF	J
C19			CK73HB1A104K	CHIP C 0.10UF	K

PARTS LIST

TX-RX UNIT (X57-6890-XX)

Ref. No.	Address	New parts	Parts No.	Description	Destination	Ref. No.	Address	New parts	Parts No.	Description	Destination
C21			C92-0713-05	CHIP-TAN 10UF 6.3VV		C67			CC73HCH1H040B	CHIP C 4.0PF B	BM3
C22			C92-0502-05	CHIP-TAN 0.33UF 35VV		C67			CC73HCH1H050B	CHIP C 5.0PF B	AK,AK2
C24			CK73HB1H102K	CHIP C 1000PF K		C67			CC73HCH1H050B	CHIP C 5.0PF B	AM,AM2
C25			CC73HCH1H020B	CHIP C 2.0PF B		C67			CC73HCH1H050B	CHIP C 5.0PF B	BM
C26			CC73HCH1H300J	CHIP C 30PF J		C68 -70			CK73HB1H471K	CHIP C 470PF K	
C27			C92-0697-05	CHIP-TAN 3.3UF 16VV		C71 ,72			CK73HB1A104K	CHIP C 0.10UF K	
C29 ,30			CK73HB1H471K	CHIP C 470PF K		C73 ,74			CC73HCH1H0R5B	CHIP C 0.5PF B	
C32			C92-0001-05	CHIP C 0.1UF 35VV		C75 ,76			CK73HB1H102K	CHIP C 1000PF K	
C33 ,34			CK73HB1H102K	CHIP C 1000PF K		C77			CK73HB1H471K	CHIP C 470PF K	
C35			CC73HCH1H270J	CHIP C 27PF J		C78			CC73HCH1H330J	CHIP C 33PF J	
C38			CC73HCH1H050B	CHIP C 5.0PF B		C79			C92-0713-05	CHIP-TAN 10UF 6.3VV	
C39			CK73GB1H332K	CHIP C 3300PF K		C80			CK73HB1H471K	CHIP C 470PF K	
C40			CC73HCH1H030B	CHIP C 3.0PF B		C83			CC73HCH1H150J	CHIP C 15PF J	
C41			CK73GB1H682K	CHIP C 6800PF K		C84 -86			CK73HB1H102K	CHIP C 1000PF K	
C42			CC73HCH1H050B	CHIP C 5.0PF B		C87			CC73HCH1H100D	CHIP C 10PF D	
C43			CC73HCH1H100C	CHIP C 10PF C		C90			CK73HB1H102K	CHIP C 1000PF K	
C44			CK73HB1H471K	CHIP C 470PF K		C100			CK73HB1H471K	CHIP C 470PF K	
C45			CK73GB1A105K	CHIP C 1.0UF K		C101			CK73GB1H471K	CHIP C 470PF K	
C47			CC73HCH1H101J	CHIP C 100PF J		C102			CC73GCH1H120J	CHIP C 12PF J	
C48			CK73HB1H471K	CHIP C 470PF K		C106			CK73HB1H471K	CHIP C 470PF K	
C49			CC73HCH1H101J	CHIP C 100PF J		C107			CC73GCH1H060B	CHIP C 6.0PF B	AK,AK2
C50			CC73HCH1H100D	CHIP C 10PF D		C107			CC73GCH1H060B	CHIP C 6.0PF B	AM,AM2
C52			CC73HCH1H110J	CHIP C 11PF J	AK,AM	C107			CC73GCH1H060B	CHIP C 6.0PF B	BM
C52			CC73HCH1H110J	CHIP C 11PF J	BM,BM3	C107			CC73GCH1H070D	CHIP C 7.0PF D	BM3
C52			CC73HCH1H120J	CHIP C 12PF J	AK2,AM2	C108			CK73HB1H471K	CHIP C 470PF K	
C53			CC73HCH1H020B	CHIP C 2.0PF B	AK,AK2	C110,111			CK73GB1H471K	CHIP C 470PF K	
C53			CC73HCH1H020B	CHIP C 2.0PF B	AM,AM2	C112			CC73GCH1H070D	CHIP C 7.0PF D	
C53			CC73HCH1H020B	CHIP C 2.0PF B	BM	C113			CK73GB1C104K	CHIP C 0.10UF K	
C53			CC73HCH1H040B	CHIP C 4.0PF B	BM3	C113			CC73GCH1H030B	CHIP C 3.0PF B	BM3
C54			CC73HCH1H060B	CHIP C 6.0PF B	AK,AM,BM	C116			CC73GCH1H110J	CHIP C 11PF J	AK,AK2
C54			CC73HCH1H070B	CHIP C 7.0PF B	BM3	C116			CC73GCH1H110J	CHIP C 11PF J	AM,AM2
C54			CC73HCH1H090B	CHIP C 9.0PF B	AK2,AM2	C116			CC73GCH1H110J	CHIP C 11PF J	BM
C55			CC73HCH1H110J	CHIP C 11PF J	AK,AM,BM	C118			CC73GCH1H470J	CHIP C 47PF J	AK2,AM2
C55			CC73HCH1H120J	CHIP C 12PF J	AK2,AM2	C119			CK73GB1H471K	CHIP C 470PF K	
C55			CC73HCH1H120J	CHIP C 12PF J	BM3	C120			CC73GCH1H150G	CHIP C 15PF G	AK2,AM2
C56			CC73HCH1H020B	CHIP C 2.0PF B	AK,AM,BM	C121			CC73GCH1H060B	CHIP C 6.0PF B	AK2,AM2
C56			CC73HCH1H050B	CHIP C 5.0PF B	BM3	C121			CC73GCH1H120J	CHIP C 12PF J	BM3
C57			CC73HCH1H0R5B	CHIP C 0.5PF B	BM3	C122			CC73GCH1H330J	CHIP C 33PF J	
C58			CC73HCH1H060B	CHIP C 6.0PF B	AK,AM,BM	C123			CC73GCH1H330G	CHIP C 33PF G	
C58			CC73HCH1H070B	CHIP C 7.0PF B	BM3	C124			CC73HCH1H100D	CHIP C 10PF D	
C58			CC73HCH1H090B	CHIP C 9.0PF B	AK2,AM2	C125			CC73GCH1H060B	CHIP C 6.0PF B	AK,AM,BM
C59			CC73HCH1H010B	CHIP C 1.0PF B	AK2,AM2	C125			CC73GCH1H080B	CHIP C 8.0PF B	BM3
C59			CC73HCH1H1R5B	CHIP C 1.5PF B	BM3	C126			C92-0004-05	CHIP-TAN 1.0UF 16VV	
C59 ,60			CC73HCH1H010B	CHIP C 1.0PF B	AK,AM,BM	C127			CC73GCH1H200J	CHIP C 20PF J	AK,AM,BM
C60			CC73HCH1H010B	CHIP C 1.0PF B	AK2,AM2	C128			CK73HB1H471K	CHIP C 470PF K	
C60			CC73HCH1H010B	CHIP C 1.0PF B	BM3	C129			CK73GB1H471K	CHIP C 470PF K	
C61			CC73HCH1H030B	CHIP C 3.0PF B	AK,AM,BM	C130			CK73HB1H471K	CHIP C 470PF K	
C61			CC73HCH1H040B	CHIP C 4.0PF B	AK2,AM2	C132			CC73GCH1H200J	CHIP C 20PF J	AK,AM,BM
C61			CC73HCH1H040B	CHIP C 4.0PF B	BM3	C132			CC73GCH1H270J	CHIP C 27PF J	AK2,AM2
C62			CC73HCH1H020B	CHIP C 2.0PF B	AK,AK2	C132			CC73GCH1H390J	CHIP C 39PF J	BM3
C62			CC73HCH1H020B	CHIP C 2.0PF B	AM,AM2	C133			CK73GB1H471K	CHIP C 470PF K	
C62			CC73HCH1H020B	CHIP C 2.0PF B	BM	C134			CK73GB1H103K	CHIP C 0.010UF K	
C62			CC73HCH1H030B	CHIP C 3.0PF B	BM3	C135			CK73GB1C104K	CHIP C 0.10UF K	
C63			CC73HCH1H101J	CHIP C 100PF J		C136			CK73GB1A105K	CHIP C 1.0UF K	
C64			CC73HCH1H040B	CHIP C 4.0PF B	AK,AM,BM	C138			CK73GB1H102K	CHIP C 1000PF K	
C64			CC73HCH1H040B	CHIP C 4.0PF B	BM3	C140			CC73GCH1H101J	CHIP C 100PF J	
C64 ,65			CC73HCH1H050B	CHIP C 5.0PF B	AK2,AM2	C145			CC73GCH1H180J	CHIP C 18PF J	AK,AK2
C65 ,66			CC73HCH1H050B	CHIP C 5.0PF B	BM3	C145			CC73GCH1H180J	CHIP C 18PF J	AM,AM2
C65 ,66			CC73HCH1H060B	CHIP C 6.0PF B	AK,AM,BM	C145			CC73GCH1H180J	CHIP C 18PF J	BM
C66			CC73HCH1H060B	CHIP C 6.0PF B	AK2,AM2	C145			CC73GCH1H300J	CHIP C 30PF J	BM3

AK : TK-3202 (K) AK2 : TH-3202 (K2) AM : TK-3202 (M) AM2 : TH-3202 (M2)
 BM : TK-3206 (M) BM3 : TH-3206 (M3)

TK-3202/3206

PARTS LIST

TX-RX UNIT (X57-6890-XX)

Ref. No.	Address	New parts	Parts No.	Description	Destination	Ref. No.	Address	New parts	Parts No.	Description	Destination
C146			CK73GB1H102K	CHIP C 1000PF K		C231			CK73GB1H103K	CHIP C 0.010UF K	
C148			CK73GB1H102K	CHIP C 1000PF K		C232			CK73HB1C103K	CHIP C 0.010UF K	
C149			CC73GCH1H070B	CHIP C 7.0PF B	AK,AM,BM	C233			CC73GCH1H060B	CHIP C 6.0PF B	
C149			CC73GCH1H070B	CHIP C 7.0PF B	BM3	C234			CK73HB1H102K	CHIP C 1000PF K	
C151			CC73GCH1H070B	CHIP C 7.0PF B	AK2,AM2	C236			CC73GCH1H180J	CHIP C 18PF J	
C151			CC73GCH1H070B	CHIP C 7.0PF B	BM3	C237			CK73HB1H102K	CHIP C 1000PF K	
C152			CC73GCH1H200J	CHIP C 20PF J	AK,AK2	C238			CK73GB1C104K	CHIP C 0.10UF K	
C152			CC73GCH1H200J	CHIP C 20PF J	AM,AM2	C239			CK73GB1H102K	CHIP C 1000PF K	
C152			CC73GCH1H200J	CHIP C 20PF J	BM	C240			CC73GCH1H010B	CHIP C 1.0PF B	BM3
C152			CC73GCH1H300J	CHIP C 30PF J	BM3	C240			CC73GCH1H3R5B	CHIP C 3.5PF B	AK,AK2
C154			CK73GB1H471K	CHIP C 470PF K		C240			CC73GCH1H3R5B	CHIP C 3.5PF B	AM,AM2
C156			CC73GCH1H030B	CHIP C 3.0PF B	BM3	C240			CC73GCH1H3R5B	CHIP C 3.5PF B	BM
C156			CC73GCH1H040B	CHIP C 4.0PF B	AK,AM,BM	C241			CK73GB1H471K	CHIP C 470PF K	
C156			CC73GCH1H3R5B	CHIP C 3.5PF B	AK2,AM2	C244			CC73GCH1H030B	CHIP C 3.0PF B	AK,AM,BM
C157			CC73GCH1H040B	CHIP C 4.0PF B	AK2,AM2	C244			CC73GCH1H3R5B	CHIP C 3.5PF B	AK2,AM2
C157			CC73GCH1H040B	CHIP C 4.0PF B	BM3	C245			CC73GCH1H180J	CHIP C 18PF J	AK2,AM2
C157			CC73GCH1H2R5B	CHIP C 2.5PF B	AK,AM,BM	C245			CC73GCH1H220J	CHIP C 22PF J	AK,AM,BM
C158			CC73GCH1H101J	CHIP C 100PF J		C246			CC73GCH1HR75B	CHIP C 0.75PF B	AK2,AM2
C159			CC73GCH1H020C	CHIP C 2.0PF C	AK,AM,BM	C246			CC73GCH1H010B	CHIP C 1.0PF B	AK,AM,BM
C159			CC73GCH1H020C	CHIP C 2.0PF C	BM3	C247			CK73HB1H471K	CHIP C 470PF K	AK,AK2
C159			CC73GCH1H030B	CHIP C 3.0PF B	AK2,AM2	C247			CK73HB1H471K	CHIP C 470PF K	AM,AM2
C160			CC73GCH1H020B	CHIP C 2.0PF B	AK,AM,BM	C247			CK73HB1H471K	CHIP C 470PF K	BM
C160			CC73GCH1H020B	CHIP C 2.0PF B	BM3	C248			CC73GCH1H010B	CHIP C 1.0PF B	AK2,AM2
C160			CC73GCH1H1R5B	CHIP C 1.5PF B	AK2,AM2	C248			CC73GCH1H020B	CHIP C 2.0PF B	AK,AM,BM
C161			CC73GCH1H050B	CHIP C 5.0PF B	AK,AM,BM	C249			CC73GCH1H050B	CHIP C 5.0PF B	BM3
C161			CC73GCH1H050B	CHIP C 5.0PF B	BM3	C249			CC73GCH1H060B	CHIP C 6.0PF B	AK,AK2
C161			CC73GCH1H060B	CHIP C 6.0PF B	AK2,AM2	C249			CC73GCH1H060B	CHIP C 6.0PF B	AM,AM2
C163			CC73GCH1H030B	CHIP C 3.0PF B		C249			CC73GCH1H060B	CHIP C 6.0PF B	BM
C164			CC73GCH1H050B	CHIP C 5.0PF B	AK,AM,BM	C250			CC73GCH1H180J	CHIP C 18PF J	AK2,AM2
C164			CC73GCH1H050B	CHIP C 5.0PF B	BM3	C250			CC73GCH1H220J	CHIP C 22PF J	AK,AM,BM
C164			CC73GCH1H060B	CHIP C 6.0PF B	AK2,AM2	C250			CC73GCH1H220J	CHIP C 22PF J	BM3
C166			CC73GCH1HR75B	CHIP C 0.75PF B	AK,AM,BM	C251			CK73HB1H471K	CHIP C 470PF K	
C166			CC73GCH1HR75B	CHIP C 0.75PF B	BM3	C252			CC73GCH1HR75B	CHIP C 0.75PF B	AK2,AM2
C166			CC73GCH1H1R5B	CHIP C 1.5PF B	AK2,AM2	C252			CC73GCH1H1R5B	CHIP C 1.5PF B	BM3
C168			CC73GCH1H0R3B	CHIP C 0.3PF B	AK2,AM2	C252,253			CC73GCH1H020B	CHIP C 2.0PF B	AK,AM,BM
C169			CC73GCH1H040B	CHIP C 4.0PF B	AK,AM,BM	C253			CC73GCH1H020B	CHIP C 2.0PF B	AK2,AM2
C169			CC73GCH1H030B	CHIP C 3.0PF B	AK2,AM2	C253			CC73GCH1H020B	CHIP C 2.0PF B	BM3
C169			CC73GCH1H100C	CHIP C 10PF C	BM3	C254			CK73HB1H471K	CHIP C 470PF K	
C190			CK73GB1A105K	CHIP C 1.0UF K		C255			CC73GCH1H180J	CHIP C 18PF J	AK2,AM2
C191			CK73GB1H103K	CHIP C 0.010UF K		C255			CC73GCH1H220J	CHIP C 22PF J	AK,AM,BM
C201			CK73GB1A224K	CHIP C 0.22UF K		C255			CC73GCH1H220J	CHIP C 22PF J	BM3
C206			CK73HB1H102K	CHIP C 1000PF K		C256			C92-0714-05	CHIP-TAN 4.7UF 6.3WV	
C207			CK73HB1H182K	CHIP C 1800PF K		C257			CC73GCH1H060B	CHIP C 6.0PF B	AK2,AM2
C208			CK73HB1H471K	CHIP C 470PF K		C257			CC73GCH1H070B	CHIP C 7.0PF B	BM3
C209			C92-0713-05	CHIP-TAN 10UF 6.3WV		C257			CC73GCH1H4R5B	CHIP C 4.5PF B	AK,AM,BM
C210			CK73HB1H471K	CHIP C 470PF K		C258			CK73HB1H471K	CHIP C 470PF K	
C211			CK73HB1C103K	CHIP C 0.010UF K		C259			CK73GB1H471K	CHIP C 470PF K	
C213			CK73HB1A104K	CHIP C 0.10UF K		C262,263			CK73HB1H471K	CHIP C 470PF K	
C214			CC73HCH1H680J	CHIP C 68PF J		C265			CK73HB1H471K	CHIP C 470PF K	
C215			CK73HB1H102K	CHIP C 1000PF K		C266			CK73GB1H471K	CHIP C 470PF K	
C216			CK73GB1C104K	CHIP C 0.10UF K		C267			CC73GCH1H050B	CHIP C 5.0PF B	AK2,AM2
C217			CK73HB1A104K	CHIP C 0.10UF K		C267			CC73GCH1H060B	CHIP C 6.0PF B	BM3
C218			CK73GB1C104K	CHIP C 0.10UF K		C267			CC73GCH1H3R5B	CHIP C 3.5PF B	AK,AM,BM
C219			CC73HCH1H330J	CHIP C 33PF J		C268			CC73GCH1H180J	CHIP C 18PF J	AK2,AM2
C220			CK73HB1H102K	CHIP C 1000PF K		C268			CC73GCH1H220J	CHIP C 22PF J	AK,AM,BM
C221			CK73GB1C104K	CHIP C 0.10UF K		C268			CC73GCH1H220J	CHIP C 22PF J	BM3
C222			CK73HB1H102K	CHIP C 1000PF K		C269			CC73GCH1H020B	CHIP C 2.0PF B	AK,AM,BM
C224,225			CK73HB1C103K	CHIP C 0.010UF K		C269			CC73GCH1H020B	CHIP C 2.0PF B	BM3
C228			CC73GCH1H100C	CHIP C 10PF C		C269			CC73GCH1H2R5B	CHIP C 2.5PF B	AK2,AM2
C230			CK73HB1C103K	CHIP C 0.010UF K		C270,271			CK73HB1H471K	CHIP C 470PF K	

PARTS LIST

TX-RX UNIT (X57-6890-XX)

Ref. No.	Address	New parts	Parts No.	Description	Destination	Ref. No.	Address	New parts	Parts No.	Description	Destination
C272			CC73GCH1H020B	CHIP C 2.0PF B		C401			CC73GCH1H471J	CHIP C 470PF J	
C273			CC73GCH1H180J	CHIP C 18PF J	AK2,AM2	C402			CK73HB1H102K	CHIP C 1000PF K	
C273			CC73GCH1H220J	CHIP C 22PF J	AK,AM,BM	C403			CK73GB1C104K	CHIP C 0.10UF K	
C273			CC73GCH1H220J	CHIP C 22PF J	BM3	C405			CC73GCH1H101J	CHIP C 100PF J	
C274			CC73GCH1H010B	CHIP C 1.0PF B	AK,AM,BM	C407			CK73HB1H102K	CHIP C 1000PF K	
C274			CC73GCH1H020B	CHIP C 2.0PF B	AK2,AM2	C409,410			CK73GB1A105K	CHIP C 1.0UF K	
C274			CC73GCH1H040B	CHIP C 4.0PF B	BM3	C411			CK73HB1H102K	CHIP C 1000PF K	
C275			CC73GCH1H020B	CHIP C 2.0PF B	AK,AM,BM	C415			CK73HB1H471K	CHIP C 470PF K	
C275			CC73GCH1H020B	CHIP C 2.0PF B	BM3	C417			CK73GB1A105K	CHIP C 1.0UF K	
C275			CC73GCH1H090B	CHIP C 9.0PF B	AK2,AM2	C418,419			CK73HB1H102K	CHIP C 1000PF K	
C276			CC73GCH1H040B	CHIP C 4.0PF B	AK2,AM2	C421			CK73GB1A105K	CHIP C 1.0UF K	
C276			CC73GCH1H040B	CHIP C 4.0PF B	BM3	C426,427			CK73GB1A105K	CHIP C 1.0UF K	
C276			CC73GCH1H3R5B	CHIP C 3.5PF B	AK,AM,BM	C428,429			CK73HB1H102K	CHIP C 1000PF K	
C290			CC73GCH1H020B	CHIP C 2.0PF B		C430			CK73GB1H103K	CHIP C 0.010UF K	
C291			CC73GCH1H060B	CHIP C 6.0PF B		C431			CK73HB1C103K	CHIP C 0.010UF K	
C292			CK73HB1H471K	CHIP C 470PF K		C432			CC73HCH1H050B	CHIP C 5.0PF B	
C301			CK73HB1H392K	CHIP C 3900PF K		C433,434			CC73HCH1H030B	CHIP C 3.0PF B	
C302			CK73HB1H271K	CHIP C 270PF K		C435			CC73HCH1H050B	CHIP C 5.0PF B	
C304			CK73GB1A224K	CHIP C 0.22UF K		C440			CC73GCH1H1R5B	CHIP C 1.5PF B	
C306			C92-0714-05	CHIP-TAN 4.7UF 6.3WV		C443			CK73GB1A474K	CHIP C 0.47UF K	
C307,308			CK73HB1A104K	CHIP C 0.10UF K		C444			CC73GCH1H020B	CHIP C 2.0PF B	BM3
C309			CC73GCH1H820J	CHIP C 82PF J		C445			CC73GCH1H180J	CHIP C 18PF J	AK2,AM2
C310			CK73HB1A683K	CHIP C 0.068UF K		TC1,2			C05-0384-05	CERAMIC TRIMMER CAP(10PF)	
C311			CK73GB1A105K	CHIP C 1.0UF K		CN201			E23-1081-05	TERMINAL	
C312			CC73GCH1H120J	CHIP C 12PF J		CN401		*	E40-6362-05	FLAT CABLE CONNECTOR	
C313			CC73GCH1H121J	CHIP C 120PF J		J301			E11-0457-05	PHONE JACK(2.5/3.5)	
C314			CK73HB1A104K	CHIP C 0.10UF K		F401			F53-0190-05	FUSE(2.5A)	
C315			CK73GB1A105K	CHIP C 1.0UF K		67	2A	*	J30-1282-04	SPACER(MIC ELEMENT)	
C316			CK73GB1C104K	CHIP C 0.10UF K		CD201			L79-1582-05	TUNING COIL	
C317			CK73HB1A104K	CHIP C 0.10UF K		CF201	2A		L72-0973-05	CERAMIC FILTER(450KHZ)	
C318			C92-0714-05	CHIP-TAN 4.7UF 6.3WV		L1			L40-4791-37	SMALL FIXED INDUCTOR(4.700UH)	
C319			CC73GCH1H271J	CHIP C 270PF J		L3			L40-5681-86	SMALL FIXED INDUCTOR(0.56UH)	
C320			CK73HB1C103K	CHIP C 0.010UF K		L5			L40-5681-86	SMALL FIXED INDUCTOR(0.56UH)	
C321			CK73GB1A105K	CHIP C 1.0UF K		L6,7			L92-0138-05	FERRITE CHIP	
C322			CK73HB1C153K	CHIP C 0.015UF K		L8,9			L40-1875-92	SMALL FIXED INDUCTOR(18NH)	
C323			CC73GCH1H820J	CHIP C 82PF J		L10,11			L40-1085-92	SMALL FIXED INDUCTOR(100NH)	
C324			CC73HCH1H820J	CHIP C 82PF J		L12			L92-0138-05	FERRITE CHIP	
C325			CK73HB1A104K	CHIP C 0.10UF K		L13,14			L40-1085-92	SMALL FIXED INDUCTOR(100NH)	
C326			CK73HB1H102K	CHIP C 1000PF K		L16			L40-1878-67	SMALL FIXED INDUCTOR(18NH)	AK2,AM2
C327			CC73HCH1H101J	CHIP C 100PF J		L16			L40-2278-67	SMALL FIXED INDUCTOR(22NH)	AK,AM,BM
C328			CK73HB1H391K	CHIP C 390PF K		L16			L40-2778-67	SMALL FIXED INDUCTOR(27NH)	BM3
C329,330			CK73GB1A105K	CHIP C 1.0UF K		L17			L40-2278-67	SMALL FIXED INDUCTOR(22NH)	AK2,AM2
C331			CK73HB1A104K	CHIP C 0.10UF K		L17			L40-2778-67	SMALL FIXED INDUCTOR(27NH)	AK,AM,BM
C332			CK73HB1H471K	CHIP C 470PF K		L17			L40-3378-67	SMALL FIXED INDUCTOR(33NH)	BM3
C333,334			CK73GB1C104K	CHIP C 0.10UF K		L18,19			L41-2285-03	SMALL FIXED INDUCTOR	
C335			CC73GCH1H221J	CHIP C 220PF J		L20,21			L40-3391-86	SMALL FIXED INDUCTOR(3.3UH)	
C336			CK73FB1C474K	CHIP C 0.47UF K		L22			L92-0138-05	FERRITE CHIP	
C338			CC73GCH1H101J	CHIP C 100PF J		L23			L40-2275-92	SMALL FIXED INDUCTOR(22NH)	
C339			C92-0560-05	CHIP-TAN 10UF 6.3WV		L24			L92-0141-05	FERRITE CHIP	
C340			CK73GB1C104K	CHIP C 0.10UF K		L25			L40-2275-92	SMALL FIXED INDUCTOR(22NH)	
C341			CK73GB1C473K	CHIP C 0.047UF K		L100			L40-3375-92	SMALL FIXED INDUCTOR(33NH)	BM3
C342			C92-0560-05	CHIP-TAN 10UF 6.3WV		L100,101			L40-1575-92	SMALL FIXED INDUCTOR(15NH)	AK,AK2
C343			CK73GB1C473J	CHIP C 0.047UF J		L100,101			L40-1575-92	SMALL FIXED INDUCTOR(15NH)	AM,AM2
C344			CC73GCH1H221J	CHIP C 220PF J		L100,101			L40-1575-92	SMALL FIXED INDUCTOR(15NH)	
C345			C92-0665-05	TANTAL 100UF 6.3WV		L101			L40-1575-92	SMALL FIXED INDUCTOR(15NH)	BM
C346			CK73GB1H102K	CHIP C 1000PF K		L102			L92-0138-05	FERRITE CHIP	BM3
C348			CK73HB1H471K	CHIP C 470PF K		L103,104			L40-8265-92	SMALL FIXED INDUCTOR(8.2NH)	
C351,352			CK73HB1C103K	CHIP C 0.010UF K							
C354			CK73HB1A104K	CHIP C 0.10UF K							
C370			CK73HB1A104K	CHIP C 0.10UF K							

AK : TK-3202 (K) AK2 : TH-3202 (K2) AM : TK-3202 (M) AM2 : TH-3202 (M2)
 BM : TK-3206 (M) BM3 : TH-3206 (M3)

TK-3202/3206

PARTS LIST

TX-RX UNIT (X57-6890-XX)

Ref. No.	Address	New parts	Parts No.	Description	Destination	Ref. No.	Address	New parts	Parts No.	Description	Destination
L105			L40-1575-54	SMALL FIXED INDUCTOR(15NH)	AK,AM,BM	R13			R92-1252-05	CHIP R	0 OHM J 1/16W
L105			L40-1575-54	SMALL FIXED INDUCTOR(15NH)	BM3	R14			RK73HB1J334J	CHIP R	330K J 1/16W
L105			L40-2275-54	SMALL FIXED INDUCTOR(22NH)	AK2,AM2	R15			RK73GB1J221J	CHIP R	220 J 1/16W
L106			L92-0149-05	FERRITE CHIP		R16			RK73GB1J561J	CHIP R	560 J 1/16W
L107			L40-1263-92	SMALL FIXED INDUCTOR(1.2NH)	AK,AM,BM	R17			RK73HB1J101J	CHIP R	100 J 1/16W
L109			L92-0149-05	FERRITE CHIP		R18			RK73GB1J181J	CHIP R	180 J 1/16W
L110			L40-2285-54	SMALL FIXED INDUCTOR(220NH)		R19			RK73GB1J122J	CHIP R	1.2K J 1/16W
L111			L40-1092-81	SMALL FIXED INDUCTOR		R20			RK73HB1J100J	CHIP R	10 J 1/16W
L130			L40-1263-92	SMALL FIXED INDUCTOR(1.2NH)	AK2,AM2	R21			RK73GB1J681J	CHIP R	680 J 1/16W
L201			L40-1091-37	SMALL FIXED INDUCTOR(1.000UH)		R22			R92-1252-05	CHIP R	0 OHM J 1/16W
L202			L92-0138-05	FERRITE CHIP		R23			RK73GB1J103J	CHIP R	10K J 1/16W
L203			L40-5685-85	SMALL FIXED INDUCTOR(0.56UH)		R25			RK73HB1J223J	CHIP R	22K J 1/16W
L204			L40-2785-92	SMALL FIXED INDUCTOR(270NH)		R26			RK73HB1J103J	CHIP R	10K J 1/16W
L206			L40-2775-92	SMALL FIXED INDUCTOR(27NH)	AK2,AM2	R27			RK73HB1J220J	CHIP R	22 J 1/16W
L206			L40-3975-92	SMALL FIXED INDUCTOR(39NH)	BM3	R30			RK73HB1J333J	CHIP R	33K J 1/16W
L211,212			L41-8268-14	SMALL FIXED INDUCTOR	AK,AK2	R31			RK73HB1J474J	CHIP R	470K J 1/16W
L211,212			L41-8268-14	SMALL FIXED INDUCTOR	AM,AM2	R32			RK73HB1J102J	CHIP R	1.0K J 1/16W
L211,212			L41-8268-14	SMALL FIXED INDUCTOR	BM	R33			RK73HB1J154J	CHIP R	150K J 1/16W
L212			L41-8268-14	SMALL FIXED INDUCTOR	BM3	R34			RK73HB1J474J	CHIP R	470K J 1/16W
L214			L41-6868-14	SMALL FIXED INDUCTOR	AK2,AM2	R35 ,36			RK73HB1J274J	CHIP R	270K J 1/16W
L214			L41-8268-14	SMALL FIXED INDUCTOR	AK,AM,BM	R37			RK73HB1J101J	CHIP R	100 J 1/16W
L214			L41-8268-14	SMALL FIXED INDUCTOR	BM3	R38			RK73HB1J181J	CHIP R	180 J 1/16W
L215			L41-2285-03	SMALL FIXED INDUCTOR		R39			RK73HB1J151J	CHIP R	150 J 1/16W
L220			L34-4602-05	AIR-CORE COIL		R40			RK73HB1J101J	CHIP R	100 J 1/16W
L223			L34-4572-05	AIR-CORE COIL	AK,AK2	R41			RK73HB1J154J	CHIP R	150K J 1/16W
L223			L34-4572-05	AIR-CORE COIL	AM,AM2	R42			RK73HB1J472J	CHIP R	4.7K J 1/16W
L223			L34-4572-05	AIR-CORE COIL	BM	R43			RK73HB1J101J	CHIP R	100 J 1/16W
L224-226			L34-4564-05	AIR-CORE COIL		R46			RK73HB1J103J	CHIP R	10K J 1/16W
L228			L41-6868-14	SMALL FIXED INDUCTOR	AK2,AM2	R47			RK73HB1J220J	CHIP R	22 J 1/16W
L228,229			L41-8268-14	SMALL FIXED INDUCTOR	AK,AM,BM	R48			RK73HB1J331J	CHIP R	330 J 1/16W
L228,229			L41-8268-14	SMALL FIXED INDUCTOR	BM3	R49			RK73HB1J222J	CHIP R	2.2K J 1/16W
L229			L41-8268-14	SMALL FIXED INDUCTOR	AK2,AM2	R50			RK73HB1J472J	CHIP R	4.7K J 1/16W
L230			L41-4778-03	SMALL FIXED INDUCTOR	AK,AK2	R100			RK73HB1J472J	CHIP R	4.7K J 1/16W
L230			L41-4778-03	SMALL FIXED INDUCTOR	AM,AM2	R103			RK73GB1J473J	CHIP R	47K J 1/16W
L230			L41-4778-03	SMALL FIXED INDUCTOR	BM	R105			RK73GB1J331J	CHIP R	330 J 1/16W
L230			L41-5678-03	SMALL FIXED INDUCTOR	BM3	R106			RK73GB1J220J	CHIP R	22 J 1/16W
L250			L40-1875-92	SMALL FIXED INDUCTOR(18NH)		R107			RK73HB1J101J	CHIP R	100 J 1/16W
L290	*		L41-3078-17	SMALL FIXED INDUCTOR	AK,AM,BM	R110			RK73GB1J331J	CHIP R	330 J 1/16W
L301			L92-0140-05	FERRITE CHIP		R111,112			R92-1252-05	CHIP R	0 OHM J 1/16W
L302			L92-0149-05	FERRITE CHIP		R114			RK73GB1J473J	CHIP R	47K J 1/16W
L401			L92-0149-05	FERRITE CHIP		R115			RK73GB1J103J	CHIP R	10K J 1/16W
L402-404			L92-0138-05	FERRITE CHIP		R116			RK73GB1J220J	CHIP R	22 J 1/16W
L410			L92-0138-05	FERRITE CHIP		R120			R92-1252-05	CHIP R	0 OHM J 1/16W
L411			L40-1875-92	SMALL FIXED INDUCTOR(18NH)		R121			RK73GB1J220J	CHIP R	22 J 1/16W
L412			L34-4564-05	AIR-CORE COIL	BM3	R123			R92-0670-05	CHIP R	0 OHM
X1			L77-1931-05	TCXO(12.8MHZ)		R123			R92-0670-05	CHIP R	0 OHM
X2	*		L78-1411-05	RESONATOR(7.37MHZ)		R124			RK73GB1J473J	CHIP R	47K J 1/16W
XF201			L71-0619-05	MCF(38.85MHZ)		R126			RK73GB1J222J	CHIP R	2.2K J 1/16W
CP404			RK75HA1J473J	CHIP-COM	47K J 1/16W	R127-129			RK73EB2ER39K	CHIP R	0.39 K 1/4W
CP405			RK75HA1J102J	CHIP-COM	1.0K J 1/16W	R130-135			RK73GH1J154D	CHIP R	150K D 1/16W
R1			RK73HB1J223J	CHIP R	22K J 1/16W	R137			R92-0670-05	CHIP R	0 OHM
R2			RK73HB1J103J	CHIP R	10K J 1/16W	R138			RK73GB1J105J	CHIP R	1.0M J 1/16W
R3			RK73HB1J333J	CHIP R	33K J 1/16W	R139			RK73GB1J473J	CHIP R	47K J 1/16W
R4			RK73HB1J563J	CHIP R	56K J 1/16W	R140			RK73GB1J563J	CHIP R	56K J 1/16W
R5			RK73HB1J104J	CHIP R	100K J 1/16W	R141			RK73GB1J104J	CHIP R	100K J 1/16W
R6			RK73HB1J823J	CHIP R	82K J 1/16W	R142			R92-1252-05	CHIP R	0 OHM J 1/16W
R7			RK73HB1J101J	CHIP R	100 J 1/16W	R143			RK73GB1J104J	CHIP R	100K J 1/16W
R8 -11			R92-1368-05	CHIP R	0 OHM	R145			R92-1252-05	CHIP R	0 OHM J 1/16W
R12			RK73HB1J222J	CHIP R	2.2K J 1/16W	R147			R92-1252-05	CHIP R	0 OHM J 1/16W
						R190			RK73GB1J101J	CHIP R	100 J 1/16W

PARTS LIST

TX-RX UNIT (X57-6890-XX)

Ref. No.	Address	New parts	Parts No.	Description	Destination	Ref. No.	Address	New parts	Parts No.	Description	Destination
R191,192			RK73GB1J271J	CHIP R 270 J 1/16W		R328			RK73GB1J103J	CHIP R 10K J 1/16W	
R193			RK73GB1J473J	CHIP R 47K J 1/16W	BM3	R329			RK73GB1J823J	CHIP R 82K J 1/16W	
R193,194			RK73GB1J473J	CHIP R 47K J 1/16W	AK,AK2	R330			RK73HB1J332J	CHIP R 3.3K J 1/16W	
R193,194			RK73GB1J473J	CHIP R 47K J 1/16W	AM,AM2	R331			RK73GB1J154J	CHIP R 150K J 1/16W	
R193,194			RK73GB1J473J	CHIP R 47K J 1/16W	BM	R332			RK73GB1J153J	CHIP R 15K J 1/16W	
R194			RK73GB1J223J	CHIP R 22K J 1/16W	BM3	R334			RK73GB1J473J	CHIP R 47K J 1/16W	
R203			RK73HB1J184J	CHIP R 180K J 1/16W		R335			RK73GB1J222J	CHIP R 2.2K J 1/16W	
R206			RK73GB1J100J	CHIP R 10 J 1/16W		R336			RK73GB1J102J	CHIP R 1.0K J 1/16W	
R207			RK73HB1J472J	CHIP R 4.7K J 1/16W		R337			RK73GB1J151J	CHIP R 150 J 1/16W	
R208			RK73HB1J823J	CHIP R 82K J 1/16W		R338			RK73GB1J222J	CHIP R 2.2K J 1/16W	
R209			RK73HB1J272J	CHIP R 2.7K J 1/16W		R339			RK73GB1J471J	CHIP R 470 J 1/16W	
R210,211			RK73GB1J332J	CHIP R 3.3K J 1/16W		R340			RK73GB1J182J	CHIP R 1.8K J 1/16W	
R212			RK73HB1J823J	CHIP R 82K J 1/16W		R341			RK73GB1J103J	CHIP R 10K J 1/16W	
R213			RK73HB1J392J	CHIP R 3.9K J 1/16W		R342			RK73GB1J101J	CHIP R 100 J 1/16W	
R215			RK73HB1J101J	CHIP R 100 J 1/16W		R343			RK73GB1J474J	CHIP R 470K J 1/16W	
R216			RK73HB1J124J	CHIP R 120K J 1/16W		R344			RK73GB1J102J	CHIP R 1.0K J 1/16W	
R217			RK73HB1J472J	CHIP R 4.7K J 1/16W		R345,346			RK73GB1J101J	CHIP R 100 J 1/16W	
R218			RK73HB1J561J	CHIP R 560 J 1/16W		R347			RK73GB1J104J	CHIP R 100K J 1/16W	
R219			RK73GB1J561J	CHIP R 560 J 1/16W		R348			RK73GB1J563J	CHIP R 56K J 1/16W	
R226,227			RK73GB1J102J	CHIP R 1.0K J 1/16W		R349			RK73GB1J333J	CHIP R 33K J 1/16W	
R228			RK73GB1J151J	CHIP R 150 J 1/16W		R350			R92-1368-05	CHIP R 0 OHM	
R233			RK73HB1J104J	CHIP R 100K J 1/16W		R354,355			RK73HB1J103J	CHIP R 10K J 1/16W	
R236			RK73HB1J563J	CHIP R 56K J 1/16W		R357			R92-1368-05	CHIP R 0 OHM	
R238			RK73HB1J104J	CHIP R 100K J 1/16W		R360			R92-1368-05	CHIP R 0 OHM	
R239			RK73HB1J563J	CHIP R 56K J 1/16W		R403			RK73GB1J101J	CHIP R 100 J 1/16W	
R240			R92-1252-05	CHIP R 0 OHM J 1/16W		R404			RK73HH1J474D	CHIP R 470K D 1/16W	
R241			RK73HB1J105J	CHIP R 1.0M J 1/16W	AK,AK2	R405			RK73GB1J334J	CHIP R 330K J 1/16W	
R241			RK73HB1J105J	CHIP R 1.0M J 1/16W	AM,AM2	R406			RK73HH1J474D	CHIP R 470K D 1/16W	
R241			RK73HB1J105J	CHIP R 1.0M J 1/16W	BM	R407			RK73HB1J334J	CHIP R 330K J 1/16W	
R243,244			RK73HB1J105J	CHIP R 1.0M J 1/16W		R408-412			RK73HB1J473J	CHIP R 47K J 1/16W	
R248			RK73GB1J221J	CHIP R 220 J 1/16W		R413,414			RK73GB1J331J	CHIP R 330 J 1/16W	
R249			RK73GB1J220J	CHIP R 22 J 1/16W		R415,416			RK73GB1J473J	CHIP R 47K J 1/16W	
R251			RK73HB1J104J	CHIP R 100K J 1/16W		R417-420			RK73HB1J473J	CHIP R 47K J 1/16W	
R253			RK73HB1J104J	CHIP R 100K J 1/16W		R421,422			RK73HB1J102J	CHIP R 1.0K J 1/16W	
R254			RK73HB1J683J	CHIP R 68K J 1/16W		R423			R92-1368-05	CHIP R 0 OHM	
R255			R92-1252-05	CHIP R 0 OHM J 1/16W		R424,425			RK73HB1J473J	CHIP R 47K J 1/16W	
R256,257			RK73HB1J105J	CHIP R 1.0M J 1/16W		R426			R92-1368-05	CHIP R 0 OHM	
R258			R92-0670-05	CHIP R 0 OHM		R435			RK73HB1J473J	CHIP R 47K J 1/16W	
R301			RK73HB1J103J	CHIP R 10K J 1/16W		R436			R92-1252-05	CHIP R 0 OHM J 1/16W	
R304			RK73HB1J273J	CHIP R 27K J 1/16W		R437,438			RK73HB1J473J	CHIP R 47K J 1/16W	
R305			RK73HB1J104J	CHIP R 100K J 1/16W		R445,446			R92-1252-05	CHIP R 0 OHM J 1/16W	
R306			RK73HB1J102J	CHIP R 1.0K J 1/16W		R447			RK73HB1J123J	CHIP R 12K J 1/16W	
R307,308			R92-1368-05	CHIP R 0 OHM		R449,450			R92-1252-05	CHIP R 0 OHM J 1/16W	BM3
R310			RK73GB1J394J	CHIP R 390K J 1/16W		R452			RK73HB1J103J	CHIP R 10K J 1/16W	
R311			RK73HB1J123J	CHIP R 12K J 1/16W		R453			RK73HB1J223J	CHIP R 22K J 1/16W	
R312			RK73GB1J334J	CHIP R 330K J 1/16W		R454			R92-1252-05	CHIP R 0 OHM J 1/16W	AK2,AM2
R313			RK73GB1J104J	CHIP R 100K J 1/16W		VR1			R12-7491-05	TRIMMING POT.(68K)	
R314			RK73GB1J103J	CHIP R 10K J 1/16W		S401-403			S70-0414-05	TACT SWITCH	
R315			RK73GB1J334J	CHIP R 330K J 1/16W		MIC301			T91-0543-05	MIC ELEMENT	
R316			RK73GB1J124J	CHIP R 120K J 1/16W		D1			MA2S111	DIODE	
R317			RK73GB1J474J	CHIP R 470K J 1/16W		D2 -9			HVC376B	VARIABLE CAPACITANCE DIODE	
R318			RK73HB1J122J	CHIP R 1.2K J 1/16W		D10			1SV278	VARIABLE CAPACITANCE DIODE	
R319			RK73HB1J563J	CHIP R 56K J 1/16W		D11			MA2S111	DIODE	
R320			RK73HB1J332J	CHIP R 3.3K J 1/16W		D101			HSC277	DIODE	
R321			RK73HB1J224J	CHIP R 220K J 1/16W		D102			HZU5CLL	ZENER DIODE	
R322			RK73HB1J184J	CHIP R 180K J 1/16W		D103,104			HVC131	DIODE	
R323			RK73HB1J563J	CHIP R 56K J 1/16W		D106			HVC131	DIODE	
R324,325			RK73GB1J104J	CHIP R 100K J 1/16W							
R326			R92-1252-05	CHIP R 0 OHM J 1/16W							
R327			RK73GB1J184J	CHIP R 180K J 1/16W							

AK : TK-3202 (K) AK2 : TH-3202 (K2) AM : TK-3202 (M) AM2 : TH-3202 (M2)
 BM : TK-3206 (M) BM3 : TH-3206 (M3)

TK-3202/3206

PARTS LIST

TX-RX UNIT (X57-6890-XX)
ADDITIONAL PCB

Ref. No.	Address	New parts	Parts No.	Description	Destination	Ref. No.	Address	New parts	Parts No.	Description	Destination
D122			HVC131	DIODE							
D202			HSC277	DIODE							
D203-206			HVC355B	VARIABLE CAPACITANCE DIODE							
D210			HVC355B	VARIABLE CAPACITANCE DIODE	AK,AK2						
D210			HVC355B	VARIABLE CAPACITANCE DIODE	AM,AM2						
D210			HVC355B	VARIABLE CAPACITANCE DIODE	BM						
D301,302			RB706F-40	DIODE							
D303			DAN222	DIODE							
D401			RB521S-30	DIODE							
D402			1SR154-400	DIODE							
IC1			MB15A02	MOS IC							
IC101			TA75W01FU	MOS IC							
IC201			TA31136FN	MOS IC							
IC301			AQUA	MOS IC							
IC302			TA7368F	MOS IC							
IC401,402			XC6204B502MR	MOS IC							
IC403		*	BD4840FVE	MOS IC							
IC404		*	BD4845FVE	MOS IC							
IC405		*	30622MAA-B89GP	MPU							
IC406		*	BR24L08F-W	ROM IC							
Q1			KTC4082	TRANSISTOR							
Q2			2SC5108(Y)	TRANSISTOR							
Q3 ,4			2SK508NV(K52)	FET							
Q5			DTA143TE	DIGITAL TRANSISTOR							
Q6			2SC5108(Y)	TRANSISTOR							
Q7			DTA143TE	DIGITAL TRANSISTOR							
Q8			2SC4617(S)	TRANSISTOR							
Q9			2SC4619	TRANSISTOR							
Q100			2SC4619	TRANSISTOR							
Q101			2SK3077	FET							
Q102			2SK2596	FET							
Q103			2SK3476	FET							
Q104			DTC114EE	DIGITAL TRANSISTOR							
Q105			2SK879(Y)	FET							
Q107			DTC114EE	DIGITAL TRANSISTOR							
Q108			2SK1824	FET							
Q109			DTA144EE	DIGITAL TRANSISTOR							
Q202			DTA144EE	DIGITAL TRANSISTOR							
Q203			2SC4649(N,P)	TRANSISTOR							
Q204,205			3SK318	FET							
Q301			DTA114EE	DIGITAL TRANSISTOR							
Q302			2SC4919	TRANSISTOR							
Q303			DTC144EE	DIGITAL TRANSISTOR							
Q304			2SA1362(GR)	TRANSISTOR							
Q305			DTC144EE	DIGITAL TRANSISTOR							
Q306			CPH3413	FET							
Q316			CPH3413	FET							
Q401,402			DTC114EE	DIGITAL TRANSISTOR							
Q403,404			CPH3317	FET							
Q405			DTA123JE	DIGITAL TRANSISTOR							
Q407,408			2SK1830	FET							
TH101			157-104-65001	THERMISTOR							
TH203			157-104-65001	THERMISTOR							
ADDITIONAL PCB											
C901,902			CK73GB1A105K	CHIP C 1.0UF K							
R901,902			RK73GB1J472J	CHIP R 4.7K J 1/16W							
Q901			2SK1824	FET							

EXPLODED VIEW

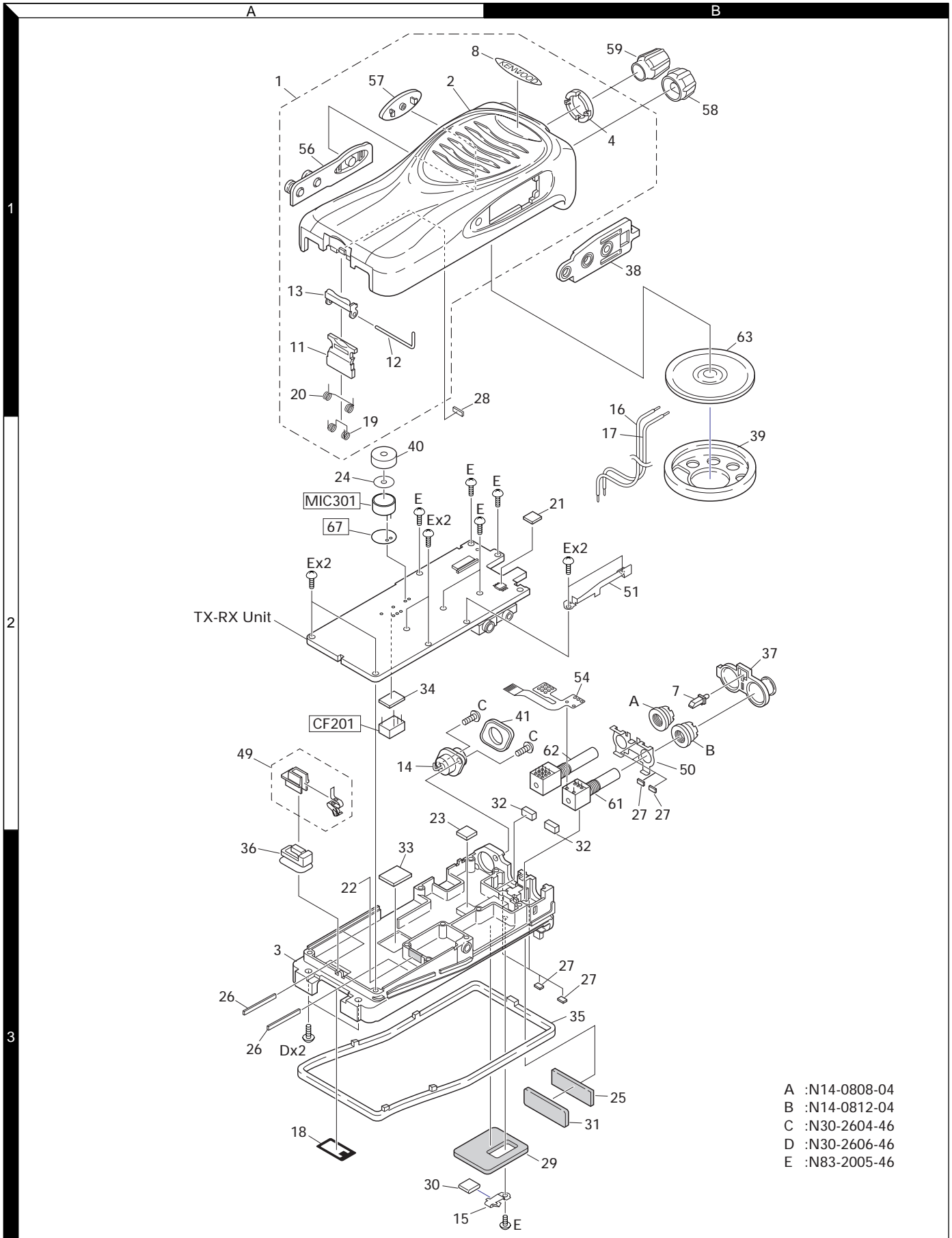

- A :N14-0808-04
- B :N14-0812-04
- C :N30-2604-46
- D :N30-2606-46
- E :N83-2005-46

TK-3202/3206

PACKING (TK-3202)

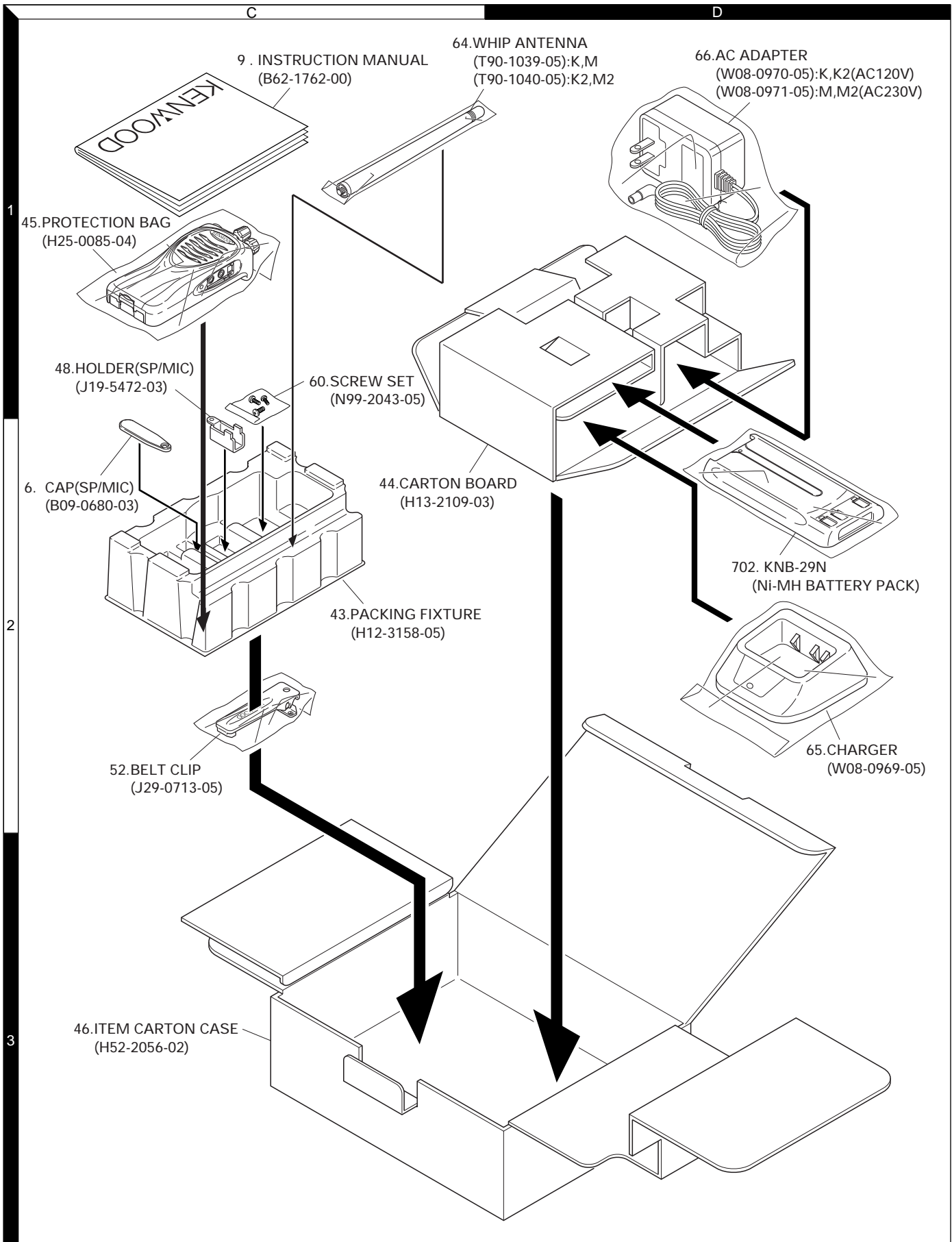

PACKING (TK-3206)

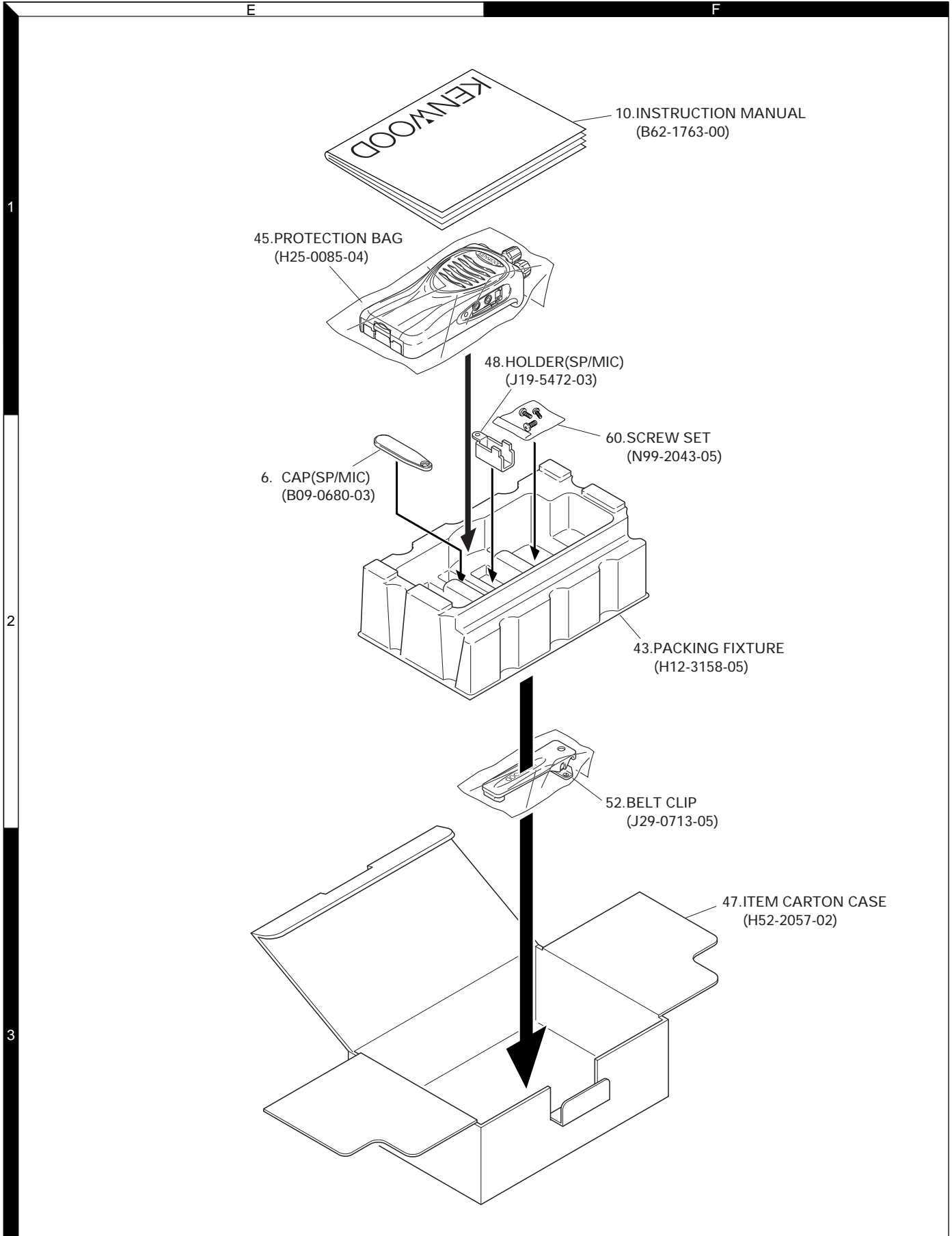

TK-3202/3206

ADJUSTMENT

Test Equipment Required for Alignment

Test Equipment	Major Specifications	
1. Standard Signal Generator (SSG)	Frequency Range	450 to 490MHz (TK-3202(K, M) TK-3206(M)) 470 to 512MHz (TK-3202(K2, M2)) 400 to 430MHz (TK-3206(M3))
	Modulation	Frequency modulation and external modulation.
	Output	-127dBm/0.1μV to greater than -47dBm/1mV
2. Power Meter	Input Impedance	50Ω.
	Operation Frequency	450 to 490MHz (TK-3202(K, M) TK-3206(M)) 470 to 512MHz (TK-3202(K2, M2)) 400 to 430MHz (TK-3206(M3))
	Measurement Range	Vicinity of 10W
3. Deviation Meter	Frequency Range	450 to 490MHz (TK-3202(K, M) TK-3206(M)) 470 to 512MHz (TK-3202(K2, M2)) 400 to 430MHz (TK-3206(M3))
4. Digital Volt Meter (DVM)	Measuring Range	10mV to 10V DC
	Input Impedance	High input impedance for minimum circuit loading.
5. Oscilloscope		DC through 30MHz.
6. High Sensitivity Frequency Counter	Frequency Range	10Hz to 1000MHz.
	Frequency Stability	0.2ppm or less.
7. Ammeter		5A.
8. AF Volt Meter (AF VTVM)	Frequency Range	50Hz to 10kHz.
	Voltage Range	1mV to 10V.
9. Audio Generator (AG)	Frequency Range	50Hz to 5kHz or more.
	Output	0 to 1V.
10. Distortion Meter	Capability	3% or less at 1kHz.
	Input Level	50mV to 10Vrms.
11. Spectrum Analyzer	Measuring Range	DC to 1GHz or more
12. Tracking Generator	Center frequency	50kHz to 600MHz
	Output Voltage	100mV or more
13. 8Ω Dummy Load		Approx. 8Ω, 3W.
14. Regulated Power Supply		5V to 10V, approx. 3A Useful if ammeter equipped.

■ The following parts are required for adjustment

1. Antenna connector adapter

The antenna connector of this radio uses an SMA terminal.

Use an antenna connector adapter [SMA(f) – BNC(f) or SMA(f) – N(f)] for adjustment. (The adapter is not provided as an option, so buy a commercially-available one.)

2. Repair Jig (Chassis)

Use jig (part No.: A10-4086-03) for repairing the TK-3202/3206. Place the TX-RX unit on the jig and fit it with screws.

The jig facilitates the voltage check and protects the final amplifier FET when the voltage on the flow side of the TX-RX unit is checked during repairs.

3. Battery Jig (W05-1011-00)

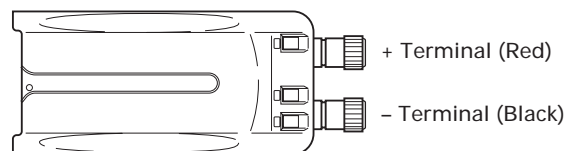

Connect the power cable properly between the battery jig installed in the transceiver and the power supply, and be sure output voltage and the power supply polarity prior to switching the power supply ON, otherwise over voltage and reverse connection may damage the transceiver, or the power supply or both.

Note: When using the battery jig, you must measure the voltage at the terminals of the battery jig. Otherwise, a slight voltage drop may occur within the power cable, between the power supply and the battery jig, especially while the transceiver transmits.

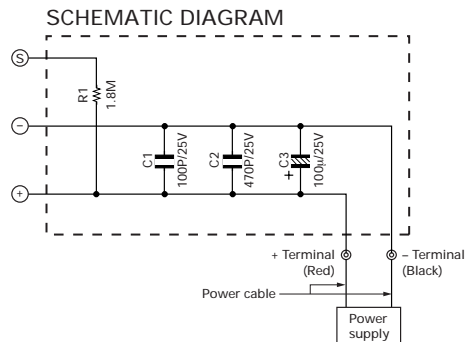

ADJUSTMENT

Adjustment points TX-RX unit (X57-689) Component side view

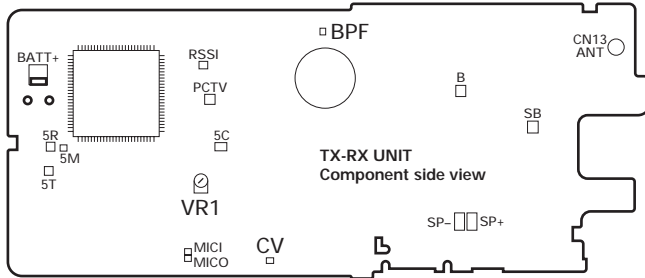

VR1 : Frequency adjustment
 BPF : Band-pass wave form test point
 CV : Lock voltage adjustment terminal

Foil Side View

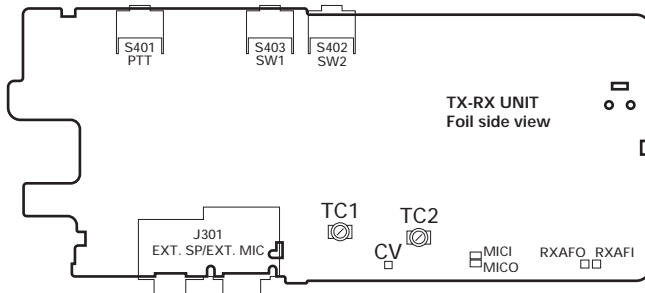

TC1 : Transmit lock voltage adjustment
 TC2 : Receive lock voltage adjustment
 CV : Lock voltage adjustment terminal

Fig. 1 Adjustment points

■ Frequency and signalling

The set has been adjusted for the frequencies shown in the following table. When required, re-adjust them following the adjustment procedure to obtain the frequencies you want in actual operation.

Frequency (MHz) K, M type (TK-3202) M type (TK-3206)

Channel No.	RX Frequency	TX Frequency
1	470.050	470.100
2	450.050	450.100
3	489.950	489.900
4	470.000	470.000
5	470.200	470.200
6	470.400	470.400
7-16	—	—

Frequency (MHz) K2, M2 type (TK-3202)

Channel No.	RX Frequency	TX Frequency
1	491.050	491.100
2	470.050	470.100
3	511.950	511.900
4	491.000	491.000
5	491.200	491.200
6	491.400	491.400
7-16	—	—

Frequency (MHz) M3 type (TK-3206)

Channel No.	RX Frequency	TX Frequency
1	415.050	415.100
2	400.050	400.100
3	429.950	429.900
4	415.000	415.000
5	415.200	415.200
6	415.400	415.400
7-16	—	—

Signalling

Signalling No.	RX	TX
1	None	None
2	None	100Hz Square Wave
3	QT 67.0Hz	QT 67.0Hz
4	QT 151.4Hz	QT 151.4Hz
5	QT 250.3Hz	QT 250.3Hz
6	DQT D023N	DQT D023N
7	DQT D754I	DQT D754I
8	DTMF 159D	DTMF 159D
9	None	DTMF tone 9

• Preparations for tuning the transceiver

Before attempting to tune the transceiver, connect the unit to a suitable power supply.

Whenever the transmitter is tuned, the unit must be connected to a suitable dummy load (i.e. power meter).

The speaker output connector must be terminated with a 8Ω dummy load and connected to an AC voltmeter and an audio distortion meter or a SINAD measurement meter at all times during tuning.

Adjustment Frequency

TEST CH	K, M type (TK-3202) M type (TK-3206)	
	RX Frequency	TX Frequency
Center	470.050MHz	470.100MHz
Low	450.050MHz	450.100MHz
High	489.950MHz	489.900MHz
Low'	460.050MHz	460.100MHz
High'	480.050MHz	480.100MHz

TEST CH	K2, M2 type (TK-3202)	
	RX Frequency	TX Frequency
Center	491.050MHz	491.100MHz
Low	470.050MHz	470.100MHz
High	511.950MHz	511.900MHz
Low'	480.550MHz	480.600MHz
High'	501.550MHz	501.600MHz

TEST CH	M3 type (TK-3206)	
	RX Frequency	TX Frequency
Center	415.050MHz	415.100MHz
Low	400.050MHz	400.100MHz
High	429.950MHz	429.900MHz
Low'	407.550MHz	407.600MHz
High'	422.550MHz	422.600MHz

TK-3202/3206

ADJUSTMENT

Common Section

Item	Condition	Measurement		Adjustment		Specifications/ Remark
		Test equipment	Terminal	Parts	Method	
1. Setting	1) BATT terminal vorage:7.5V 2) SSG standard modulation [Wide] MOD:1kHz,DEV:3kHz [Narrow] MOD:1kHz,DEV:1.5kHz					
2. VCO lock voltage RX	1) CH:High	Power meter DVM	ANT CV	TC2	3.4V (TK-3202 (K,M), TK-3206 (M)) 3.2V (TK-3202 (K2,M2)) 3.0V (TK-3206 (M3))	±0.1V
	2) CH:Low				Check	0.6V or more
3. VCO lock voltage TX	3) CH:High PTT:ON			TC1	3.1V (TK-3202 (K,M), TK-3206 (M)) 3.2V (TK-3202 (K2,M2)) 3.0V (TK-3206 (M3))	±0.1V
	4) CH:Low PTT:ON				Check	0.6V or more

Transmitter Section

Item	Condition	Measurement		Adjustment		Specifications/ Remark
		Test equipment	Terminal	Parts	Method	
1. Frequency Adjust	1) CH:High 2) PTT:ON	Frequency counter	ANT	VR1		High frequency ±50Hz
2. High power Adjust	TEST CH: Low Low' Center High' High (5 points) BATT terminal voltage:7.5V PTT:ON	Power meter Ammeter		Programming Software:KPG-87D		4.0W ±0.1W 1.9 A or less
3. Low power Adjust	TEST CH: Low Low' Center High' High (5 points) BATT terminal voltage:7.5V PTT:ON					1.0W ±0.1W 0.9 A or less
4. Max deviation Adjust [Wide]	TEST CH: Center Low High (3 points) AG:1kHz/150mV Deviation meter filter LPF:15kHz HPF:OFF PTT:ON	Power meter Deviation meter Oscilloscope AG AF VTVM	ANT SP/MIC connector			4.2kHz (According to the lager +,-)
[Narrow]	TEST CH: Center PTT:ON				2.2kHz (According to the lager +,-)	±50Hz
5. VOX 1 Writing	TEST CH: Center AG:1kHz/45mV					

ADJUSTMENT

Item	Condition	Measurement		Adjustment		Specifications/ Remark
		Test equipment	Terminal	Parts	Method	
6. VOX 10 Writing	TEST CH: Center AG: 1kHz/3.0mV	Power meter Deviation meter	ANT SP/MIC connector	Programming Software: KPG-87D		
7. DQT Balance Adjust [Wide]	TEST CH: Center Low High (3 points) LPF: 3kHz HPF: OFF PTT: ON	Oscilloscope AG AF VTVM	ANT	Programming Software: KPG-87D	Make the demodulation wave into square waves	
[Narrow]	TEST CH: Center PTT: ON					
8. QT Deviation Adjust [Wide]	TEST CH: Center Low High (3 points) LPF: 3kHz HPF: OFF PTT: ON				0.75kHz	±40Hz
[Narrow]	TEST CH: Center PTT: ON				0.35kHz	±40Hz
9. DQT Deviation Adjust [Wide]	TEST CH: Center Low High (3 points) LPF: 3kHz HPF: OFF PTT: ON				0.75kHz	±40Hz
[Narrow]	TEST CH: Center PTT: ON				0.35kHz	±40Hz
10. DTMF Deviation Adjust [Wide]	TEST CH: Center LPF: 15kHz HPF: OFF PTT: ON				3.0kHz	±100Hz
[Narrow]	TEST CH: Center PTT: ON				1.5kHz	±100Hz
11. MSK Deviation Adjust [Wide]	TEST CH: Center Low High (3 points) LPF: 15kHz HPF: OFF PTT: ON				3.0kHz	±100Hz
[Narrow]	TEST CH: Center PTT: ON				1.5kHz	±100Hz

ADJUSTMENT

Receiver Section

Item	Condition	Measurement		Adjustment		Specifications/ Remark
		Test equipment	Terminal	Parts	Method	
1. BPF Wave Adjust TK-3202 (K,M) TK-3206 (M)	(1)Center frequency Spectrum analyzer setting Center-f : 470MHz Span : 100MHz RBW : 300kHz VBW : 10kHz ATT : 5dB (2)High-edge frequency Spectrum analyzer setting Center-f : 490MHz (3)Low-edge frequency Spectrum analyzer setting Center-f : 450MHz	Spectrum analyzer	ANT BPF	Programming Software: KPG-87D	Adjust the waveform as shown to the right.	
TK-3202 (K2,M2)	(1)Center frequency Spectrum analyzer setting Center-f : 415MHz Span : 100MHz RBW : 300kHz VBW : 10kHz ATT : 5dB (2)High-edge frequency Spectrum analyzer setting Center-f : 430MHz (3)Low-edge frequency Spectrum analyzer setting Center-f : 400MHz					
TK-3206 (M3)	(1)Center frequency Spectrum analyzer setting Center-f : 491MHz Span : 100MHz RBW : 300kHz VBW : 10kHz ATT : 5dB (2)High-edge frequency Spectrum analyzer setting Center-f : 512MHz (3)Low-edge frequency Spectrum analyzer setting Center-f : 470MHz					

ADJUSTMENT

Item	Condition	Measurement		Adjustment		Specifications/ Remark
		Test equipment	Terminal	Parts	Method	
2.Sensitivity check [Wide]	TEST CH: Low Center High SSG otuput:-117 dBm(0.3μV) SSG MOD:3.0kHz	SSG DVM Oscilloscope AF VTVM	ANT		Check	12dB SINAD or more
	[Narrow]					
3.SQL1 (Threshold) writing [Wide]	TEST CH: Center Low High SSG otuput:-123 dBm(0.16μV) SSG MOD:3.0kHz			Programming Software: KPG-87D	Write	Squelch open
	[Narrow]					
4.SQL9 (Tight) writing [Wide]	TEST CH: Center Low High SSG otuput:-117 dBm(0.3μV) SSG MOD:3.0kHz					
	[Narrow]					
5.BATT Detection Writing	BATT terminal voltage:5.9V	DVM	ANT BATT terminal		Write	BATT terminal voltage:5.9V

TK-3202/3206 PC BOARD

TX-RX UNIT (X57-6890-XX) Component side view (J72-0913-09)

-20 : K,M (TK-3202), M (TK-3206) -22 : M3 (TK-3206) -23 : K2,M2 (TK-3202)

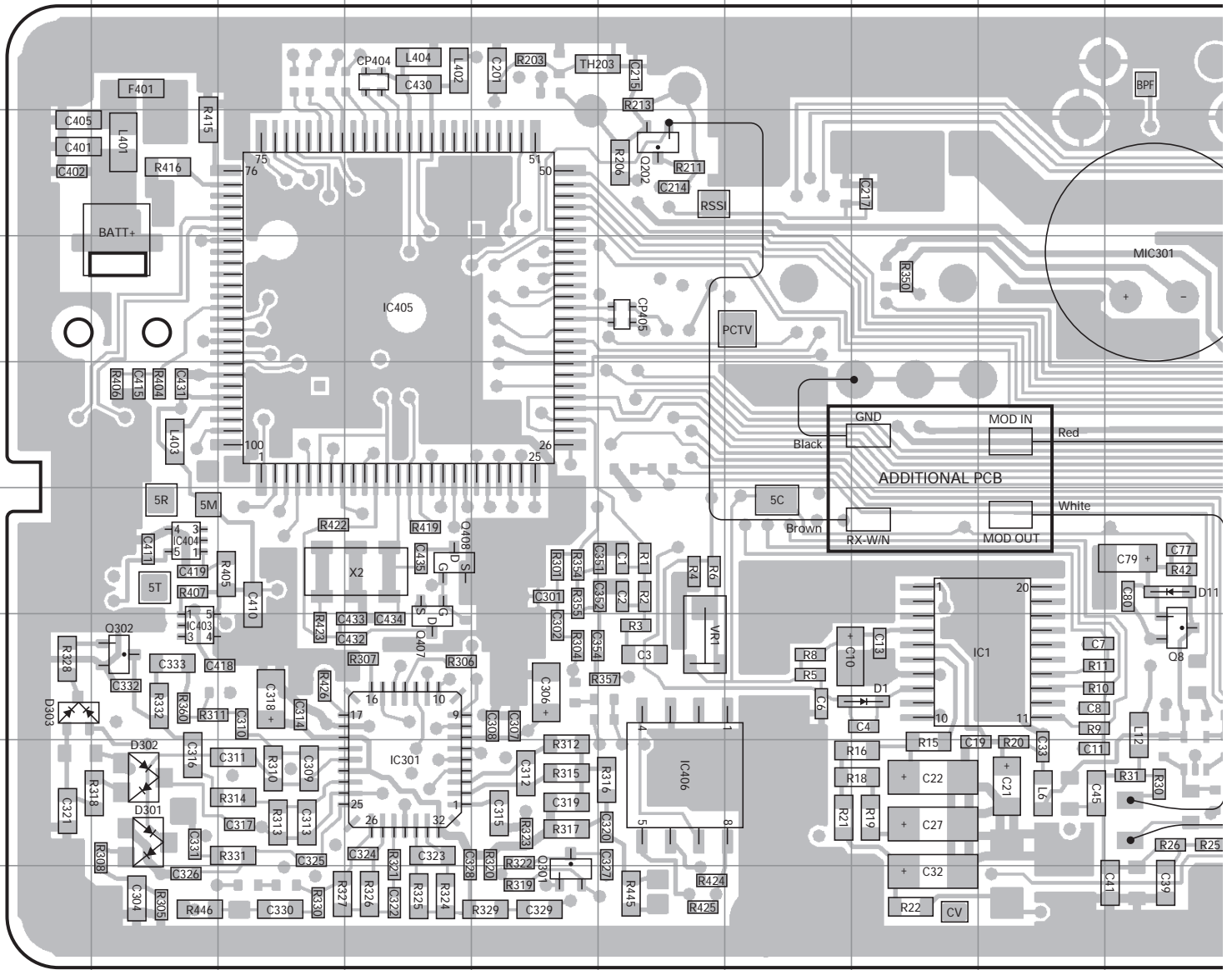

Ref. No.	Address	Ref. No.	Address	Ref. No.	Address	Ref. No.	Address
IC1	8I	Q104	5L	Q304	7P	D11	7J
IC101	4M	Q105	4K	Q305	8O	D102	4M
IC301	9D	Q107	4L	Q306	9P	D301	9B
IC302	8P	Q108	4L	Q316	9O	D302	9B
IC403	8B	Q109	5L	Q401	8R	D303	8A
IC404	7B	Q202	4F	Q402	8R	D403	8R
IC405	5D	Q301	10E	Q407	8D	D404	8R
IC406	9F	Q302	8B	Q408	7D		
Q8	8J	Q303	7P	D1	8H		

ADDITIONAL PCB

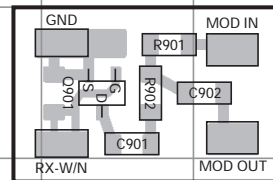

PC BOARD TK-3202/3206

TX-RX UNIT (X57-6890-XX) Component side view (J72-0913-09)
-20 : K,M (TK-3202), M (TK-3206) -22 : M3 (TK-3206) -23 : K2,M2 (TK-3202)

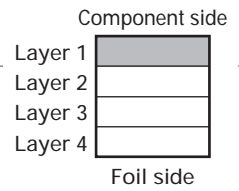
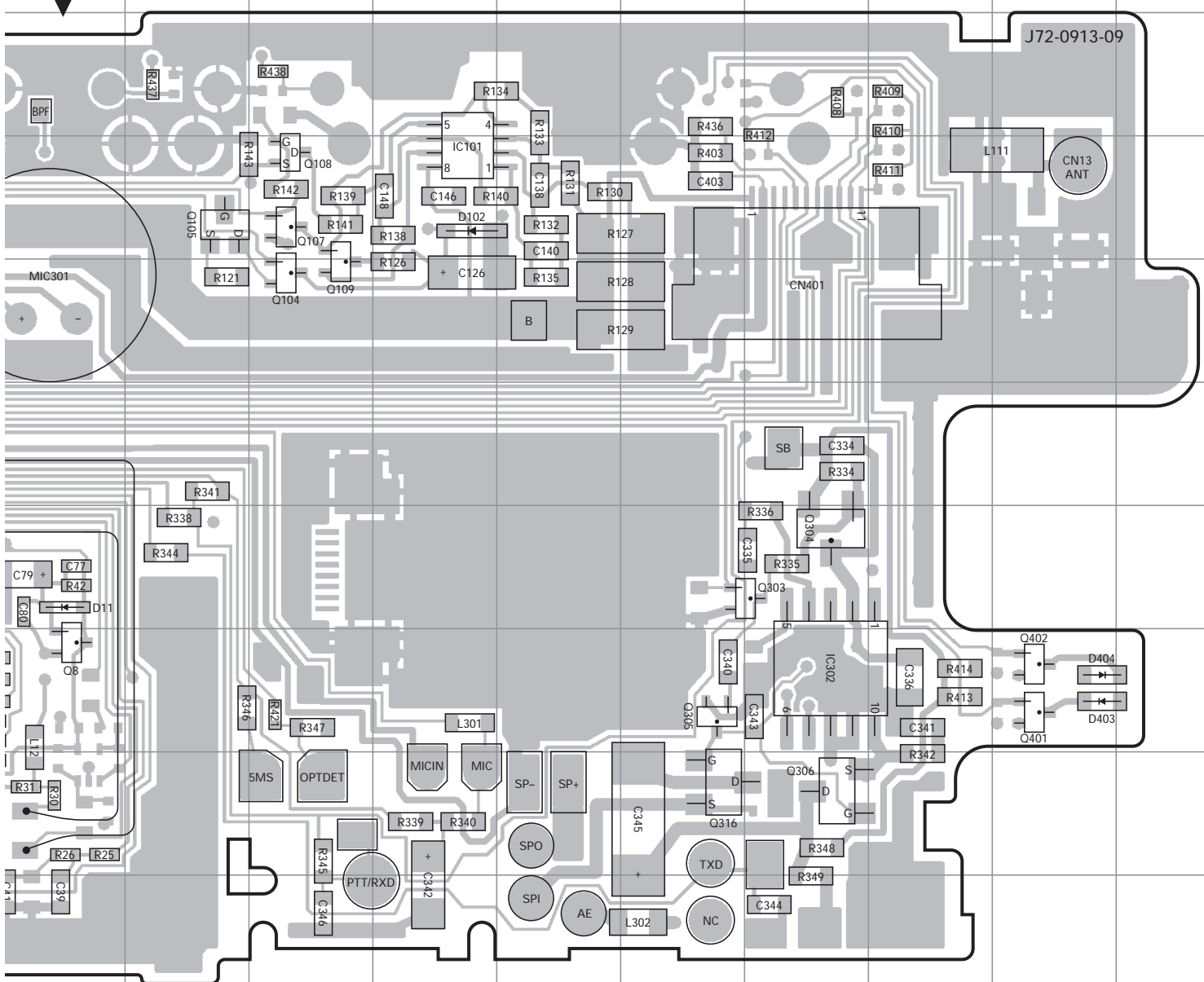

TK-3202/3206 PC BOARD

TX-RX UNIT (X57-6890-XX) Foil side view (J72-0913-09)

-20 : K,M (TK-3202), M (TK-3206) -22 : M3 (TK-3206) -23 : K2,M2 (TK-3202)

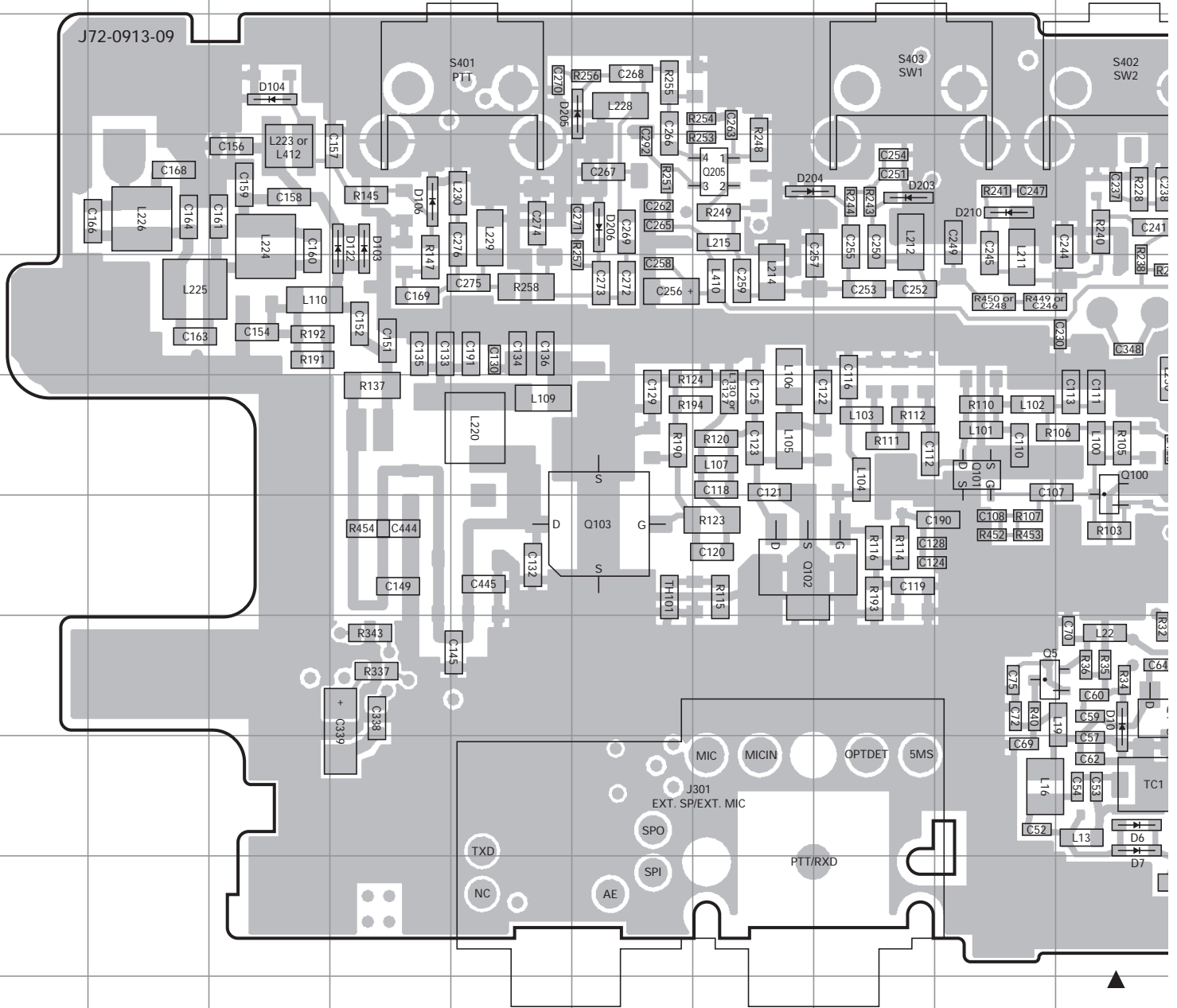

Ref. No.	Address	Ref. No.	Address	Ref. No.	Address	Ref. No.	Address	Ref. No.	Address	Ref. No.	Address
IC201	5N	Q6	8K	Q204	4K	D5	10L	D104	3C	D210	4I
IC401	9R	Q7	9L	Q205	4G	D6	9J	D106	4D	D401	7R
IC402	8R	Q9	6L	Q403	8R	D7	9J	D122	4D	D402	4R
Q1	7O	Q100	6J	Q404	7R	D8	10L	D202	6K		
Q2	8L	Q101	6I	Q405	9R	D9	10L	D203	4H		
Q3	9M	Q102	7G	D2	9K	D10	8J	D204	4G		
Q4	8J	Q103	7F	D3	10M	D101	6K	D205	3F		
Q5	8I	Q203	4N	D4	9J	D103	4D	D206	4F		

PC BOARD TK-3202/3206

TX-RX UNIT (X57-6890-XX) Foil side view (J72-0913-09)

-20 : K,M (TK-3202), M (TK-3206) -22 : M3 (TK-3206) -23 : K2,M2 (TK-3202)

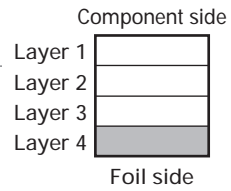
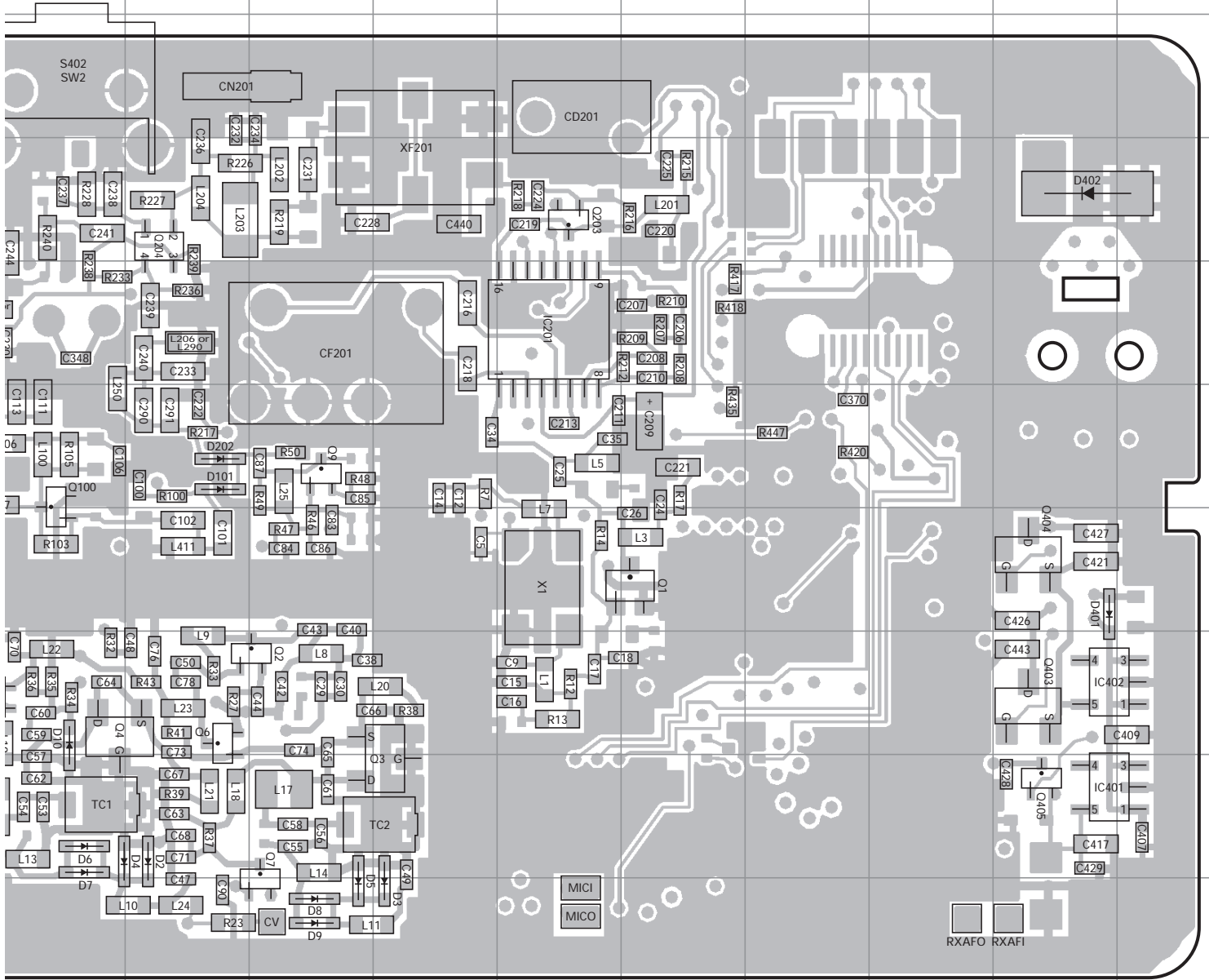

TK-3202/3206 PC BOARD

PC BOARD TK-3202/3206

TX-RX UNIT (X57-6890-XX) Component side view (J72-0913-09)
 -20 : K,M (TK-3202), M (TK-3206) -22 : M3 (TK-3206) -23 : K2,M2 (TK-3202)

TX-RX UNIT (X57-6890-XX) Component side view (J72-0913-09)
 -20 : K,M (TK-3202), M (TK-3206) -22 : M3 (TK-3206) -23 : K2,M2 (TK-3202)

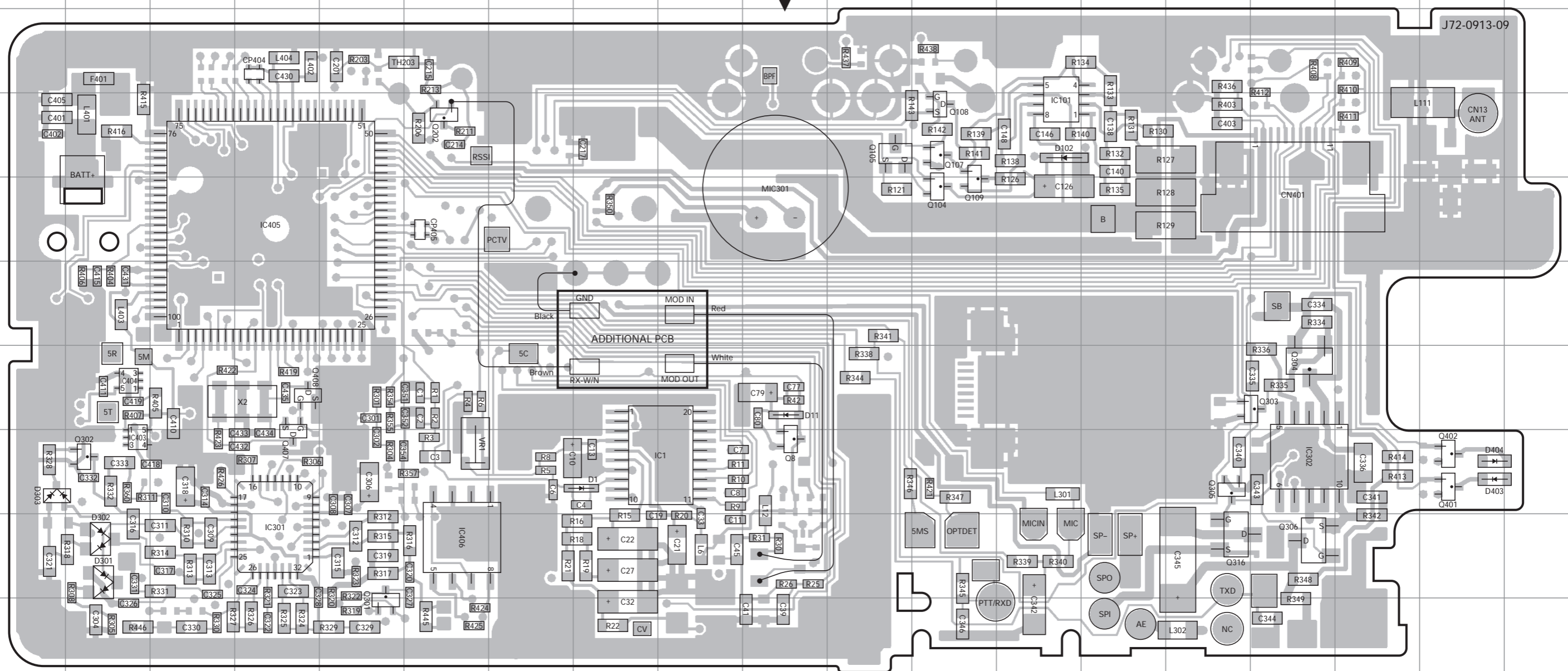

ADDITIONAL PCB

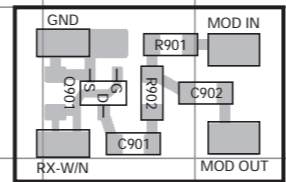

Ref. No.	Address	Ref. No.	Address	Ref. No.	Address	Ref. No.	Address
IC1	8I	Q104	5L	Q304	7P	D11	7J
IC101	4M	Q105	4K	Q305	8O	D102	4M
IC301	9D	Q107	4L	Q306	9P	D301	9B
IC302	8P	Q108	4L	Q316	9O	D302	9B
IC403	8B	Q109	5L	Q401	8R	D303	8A
IC404	7B	Q202	4F	Q402	8R	D403	8R
IC405	5D	Q301	10E	Q407	8D	D404	8R
IC406	9F	Q302	8B	Q408	7D		
Q8	8J	Q303	7P	D1	8H		

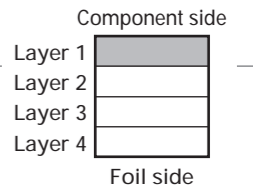

TK-3202/3206 PC BOARD

PC BOARD TK-3202/3206

TX-RX UNIT (X57-6890-XX) Foil side view (J72-0913-09)
 -20 : K,M (TK-3202), M (TK-3206) -22 : M3 (TK-3206) -23 : K2,M2 (TK-3202)

TX-RX UNIT (X57-6890-XX) Foil side view (J72-0913-09)
 -20 : K,M (TK-3202), M (TK-3206) -22 : M3 (TK-3206) -23 : K2,M2 (TK-3202)

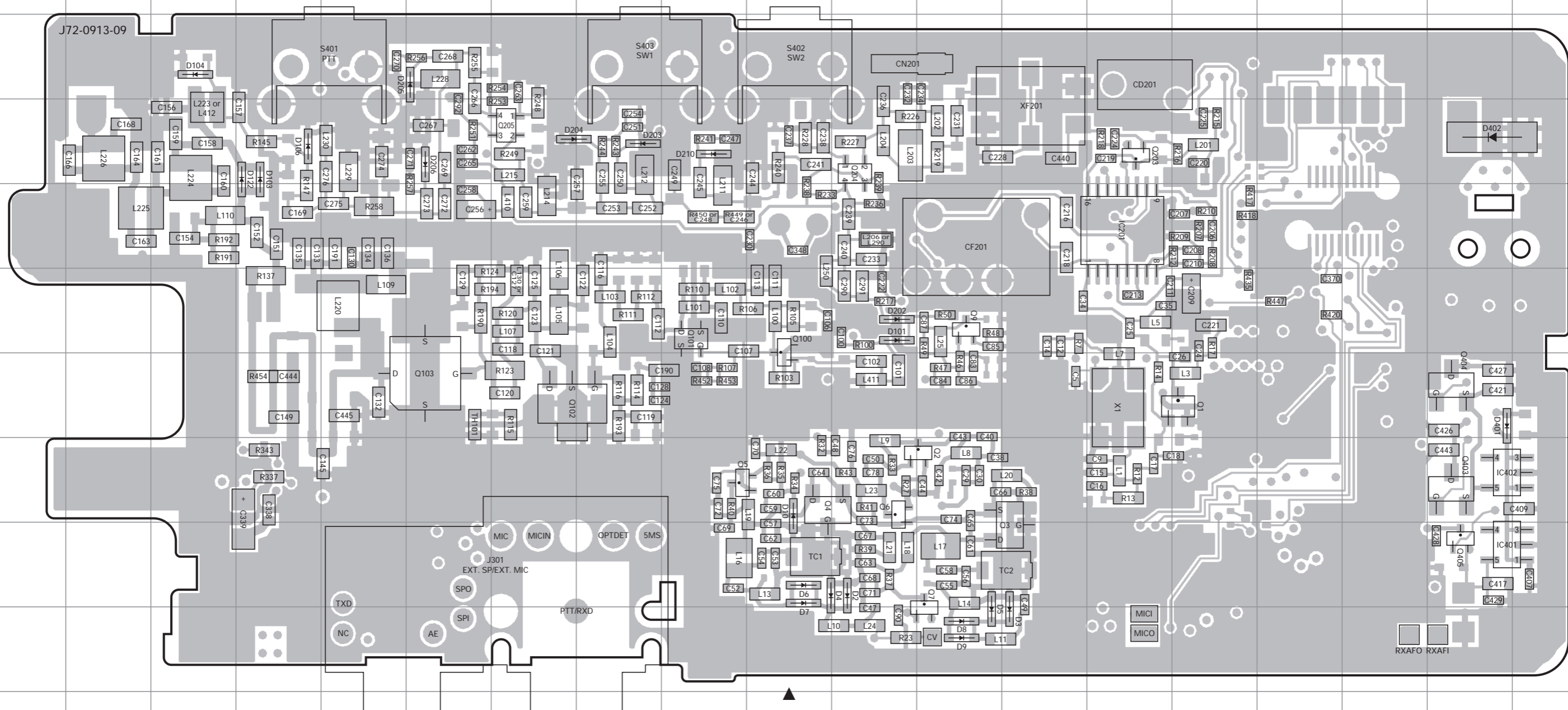

Ref. No.	Address	Ref. No.	Address	Ref. No.	Address	Ref. No.	Address	Ref. No.	Address	Ref. No.	Address
IC201	5N	Q6	8K	Q204	4K	D5	10L	D104	3C	D210	4I
IC401	9R	Q7	9L	Q205	4G	D6	9J	D106	4D	D401	7R
IC402	8R	Q9	6L	Q403	8R	D7	9J	D122	4D	D402	4R
Q1	7O	Q100	6J	Q404	7R	D8	10L	D202	6K		
Q2	8L	Q101	6I	Q405	9R	D9	10L	D203	4H		
Q3	9M	Q102	7G	D2	9K	D10	8J	D204	4G		
Q4	8J	Q103	7F	D3	10M	D101	6K	D205	3F		
Q5	8I	Q203	4N	D4	9J	D103	4D	D206	4F		

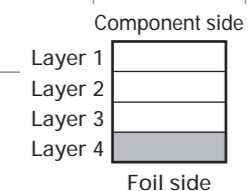

TK-3202/3206 SCHEMATIC DIAGRAM

TX-RX UNIT (X57-6890-XX)

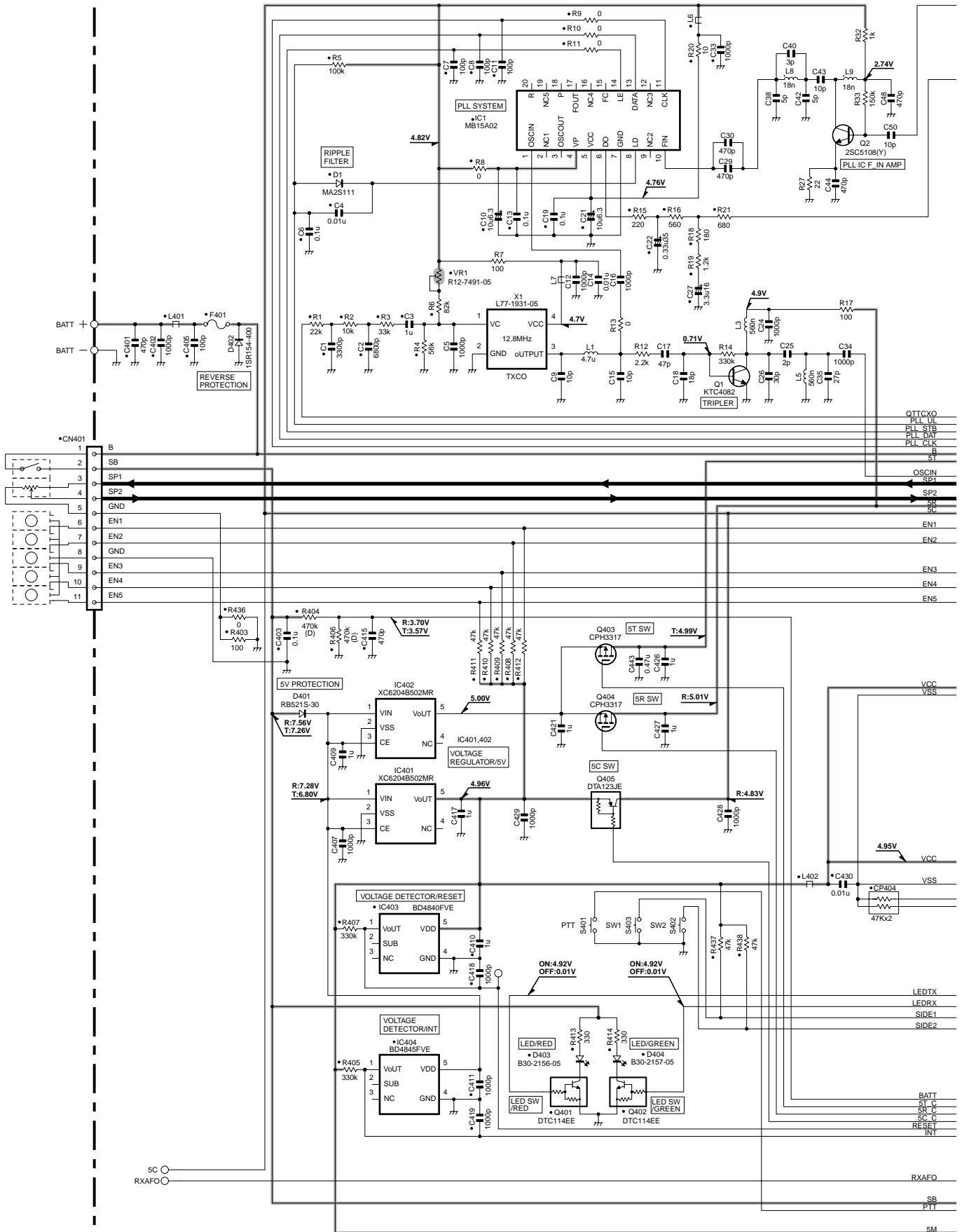

SCHEMATIC DIAGRAM TK-3202/3206

TX-RX UNIT (X57-689-XX)

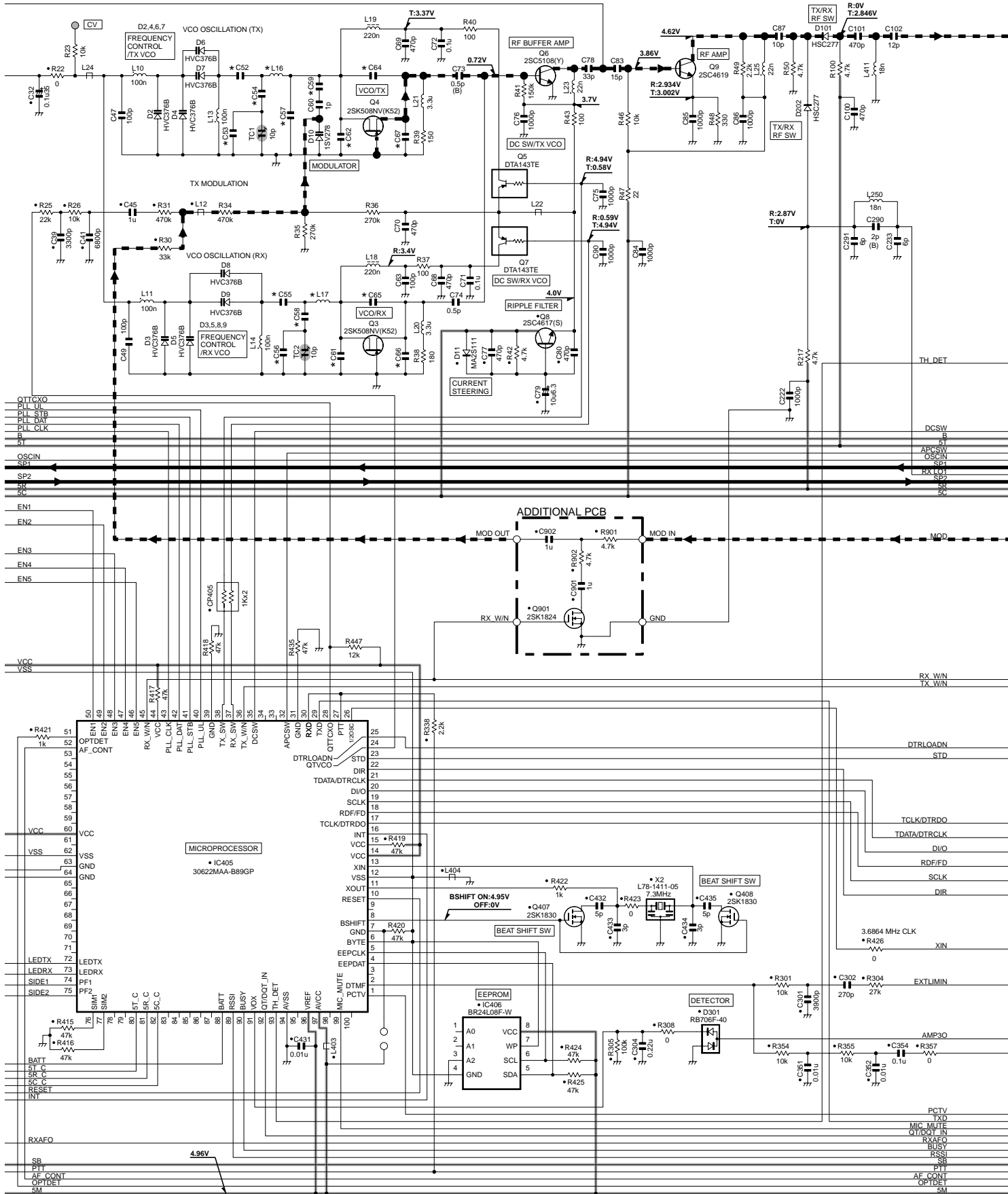

TK-3202/3206 SCHEMATIC DIAGRAM

TX-RX UNIT (X57-6890-XX)

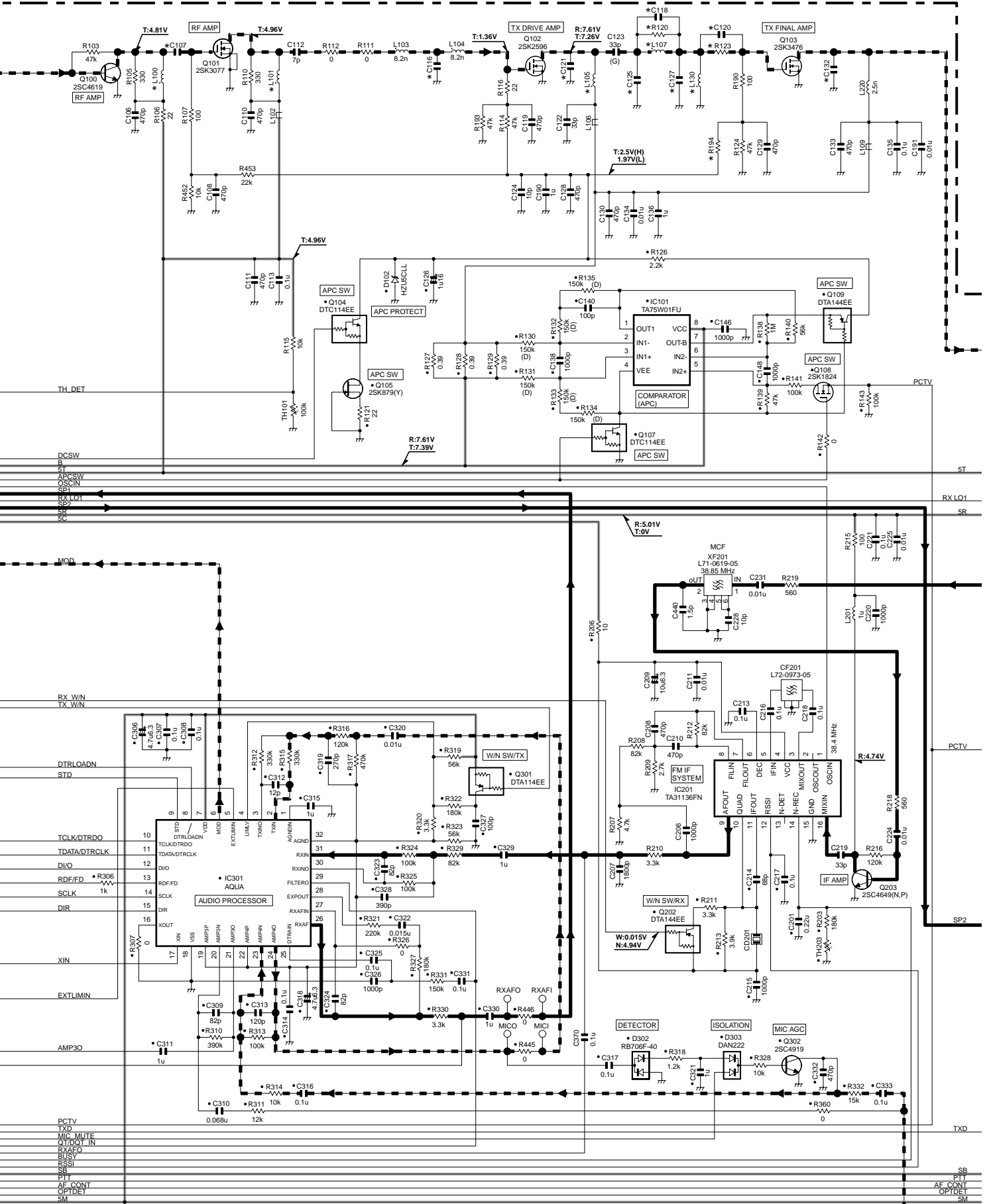

SCHEMATIC DIAGRAM TK-3202/3206

X57-6890-XX	D210	L16	L17	L100	L101	L105	L107	L130	L206	L211	L214	L223	L228	L230	L290	L412	R120	R123	R194	R241	R449	R450	R454
-20 TK-3202 TK-3206	K,M	M	HVC355B	22n	27n	15n	15n	1.2n	NO	NO	NO	L34-4572-05	8.2n	47n	30n	NO	NO	0	47k	1.0M	NO	NO	NO
-22 TK-3206	M3	NO	NO	27n	33n	33n	22n	15n	NO	NO	39n	NO	8.2n	NO	NO	L34-4564-05	0	0	22k	NO	0	0	0
-23 TK-3202	K2,M2	HVC355B	18n	22n	15n	15n	22n	NO	1.2n	27n	8.2n	6.8n	L34-4572-05	6.8n	47n	NO	NO	NO	47k	1.0M	NO	NO	NO

X57-6890-XX	C52	C53	C54	C55	C56	C57	C58	C59	C61	C62	C64	C65	C66	C67	C107	C116	C120	C121	C125	C127	C132	C145	C149	C151	C152	C156	C157		
-20 TK-3202 TK-3206	K,M	M	11p	2p	6p	11p	2p	NO	6p	1p	3p	2p	4p	6p	5p	6p	11p	NO	NO	NO	6p	20p	20p	18p	7p	NO	20p	4p	2.5p
-22 TK-3206	M3	11p	4p	7p	12p	5p	0.5p	7p	1.5p	4p	3p	4p	5p	5p	4p	7p	3p	NO	NO	12p	8p	NO	39p	30p	7p	7p	30p	3p	4p
-23 TK-3202	K2,M2	12p	2p	9p	12p	NO	NO	9p	1p	4p	2p	5p	5p	6p	5p	6p	11p	47p	15p	6p	NO	NO	27p	18p	NO	7p	20p	3.5p	4p

X57-6890-XX	C159	C160	C161	C164	C166	C168	C169	C240	C244	C245	C246	C247	C248	C249	C250	C252	C255	C257	C267	C268	C269	C273	C274	C275	C276	C444	C445	
-20 TK-3202 TK-3206	K,M	M	2p	2p	5p	5p	0.75p	NO	4p	3.5p	3p	22p	1p	470p	2p	6p	22p	4.5p	3.5p	22p	2p	22p	1p	2p	3.5p	NO	NO	
-22 TK-3206	M3	2p	2p	5p	5p	0.75p	NO	10p	1p	NO	NO	NO	NO	NO	5p	22p	1.5p	22p	7p	6p	22p	2p	22p	4p	2p	4p	2p	NO
-23 TK-3202	K2,M2	3p	1.5p	6p	6p	1.5p	0.3p	3p	3.5p	3.5p	18p	0.75p	470p	1p	6p	18p	0.75p	18p	6p	5p	18p	2.5p	18p	2p	9p	4p	NO	18p

Note : The components marked with a dot (●) are parts of layer1.

TX-RX UNIT (X57-6890-XX)

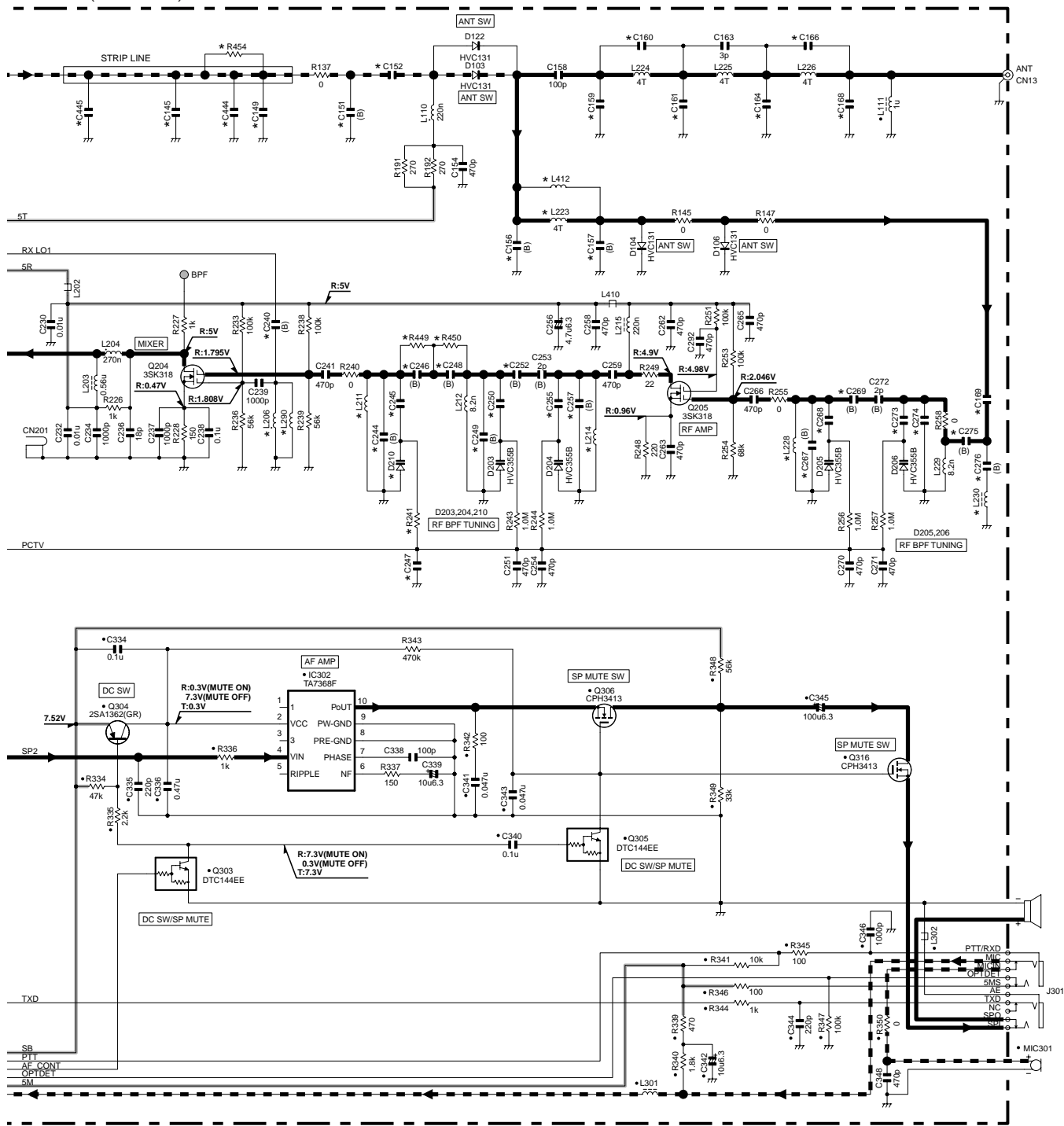

TK-3202/3206 SCHEMATIC DIAGRAM

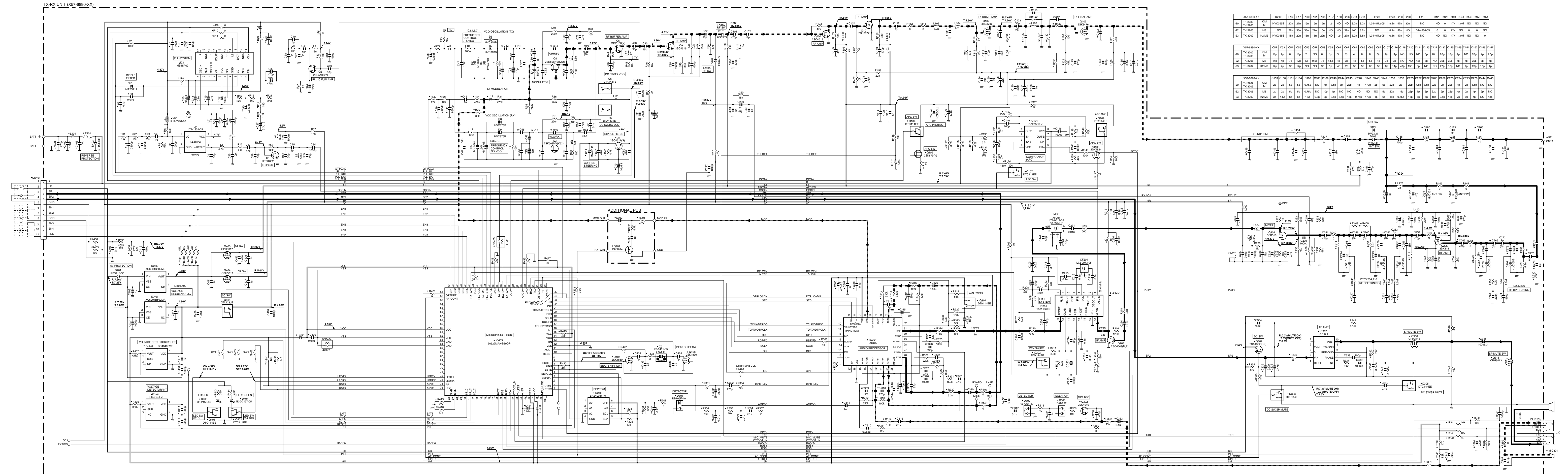

X57-6890-XX	D210	L16	L17	L100	L101	L105	L107	L130	L206	L211	L214	L223	L228	L230	L290	L412	R120	R123	R194	R241	R448	R450	R454
-20 TK-3202	KM	HVC3588	22n	27n	15n	15n	1.2n	NO	NO	8.2n	8.2n	L34-4572-05	8.2n	47n	30n	NO	NO	0	47k	1.0M	NO	NO	NO
-21 TK-3206	M3	NO	27n	33n	33n	22n	15n	NO	NO	39n	NO	NO	8.2n	NO	8.2n	56n	NO	0	22k	NO	0	0	0
-22 TK-3202	K2.M2	HVC3588	18n	22n	15n	15n	1.2n	NO	NO	1.2n	27n	8.2n	8.2n	L34-4572-05	8.2n	47n	NO	NO	0	47k	1.0M	NO	NO

X57-6890-XX	C52	C53	C54	C55	C56	C57	C58	C59	C61	C62	C64	C65	C66	C67	C107	C116	C118	C120	C121	C125	C127	C132	C145	C149	C151	C152	C156	C158	
-20 TK-3202	KM	11p	2p	6p	11p	2p	NO	6p	1p	3p	2p	4p	6p	5p	6p	15p	NO	NO	NO	NO	6p	20p	20p	18p	7p	NO	20p	4p	2.5p
-21 TK-3206	M3	11p	4p	7p	12p	5p	0.5p	7p	1.5p	4p	3p	4p	5p	5p	5p	4p	7p	3p	NO	NO	12p	8p	NO	30p	30p	7p	30p	3p	4p
-22 TK-3202	K2.M2	12p	2p	5p	12p	NO	NO	9p	1p	4p	2p	5p	6p	5p	6p	5p	6p	11p	47p	15p	6p	NO	27p	18p	NO	7p	20p	3.5p	4p

X57-6890-XX	C199	C160	C161	C164	C166	C168	C169	C240	C244	C246	C247	C248	C249	C250	C255	C257	C267	C268	C269	C273	C274	C275	C276	C444	C445				
-20 TK-3202	KM	2p	2p	5p	5p	0.75p	NO	4p	3.5p	3p	22p	1p	NO	NO	NO	NO	5p	22p	2p	22p	1.5p	22p	7p	6p	2p	4p	2p	NO	
-21 TK-3206	M3	11p	4p	7p	12p	5p	0.5p	7p	1.5p	4p	3p	4p	5p	5p	5p	5p	5p	5p	5p	5p	5p	5p	5p	5p	5p	5p	5p	5p	NO
-22 TK-3202	K2.M2	3p	1.5p	6p	6p	1.5p	0.3p	3p	3.5p	3.5p	16p	0.75p	47p	1p	6p	18p	0.75p	18p	6p	5p	18p	2.5p	18p	2p	8p	4p	NO	NO	18p

BLOCK DIAGRAM

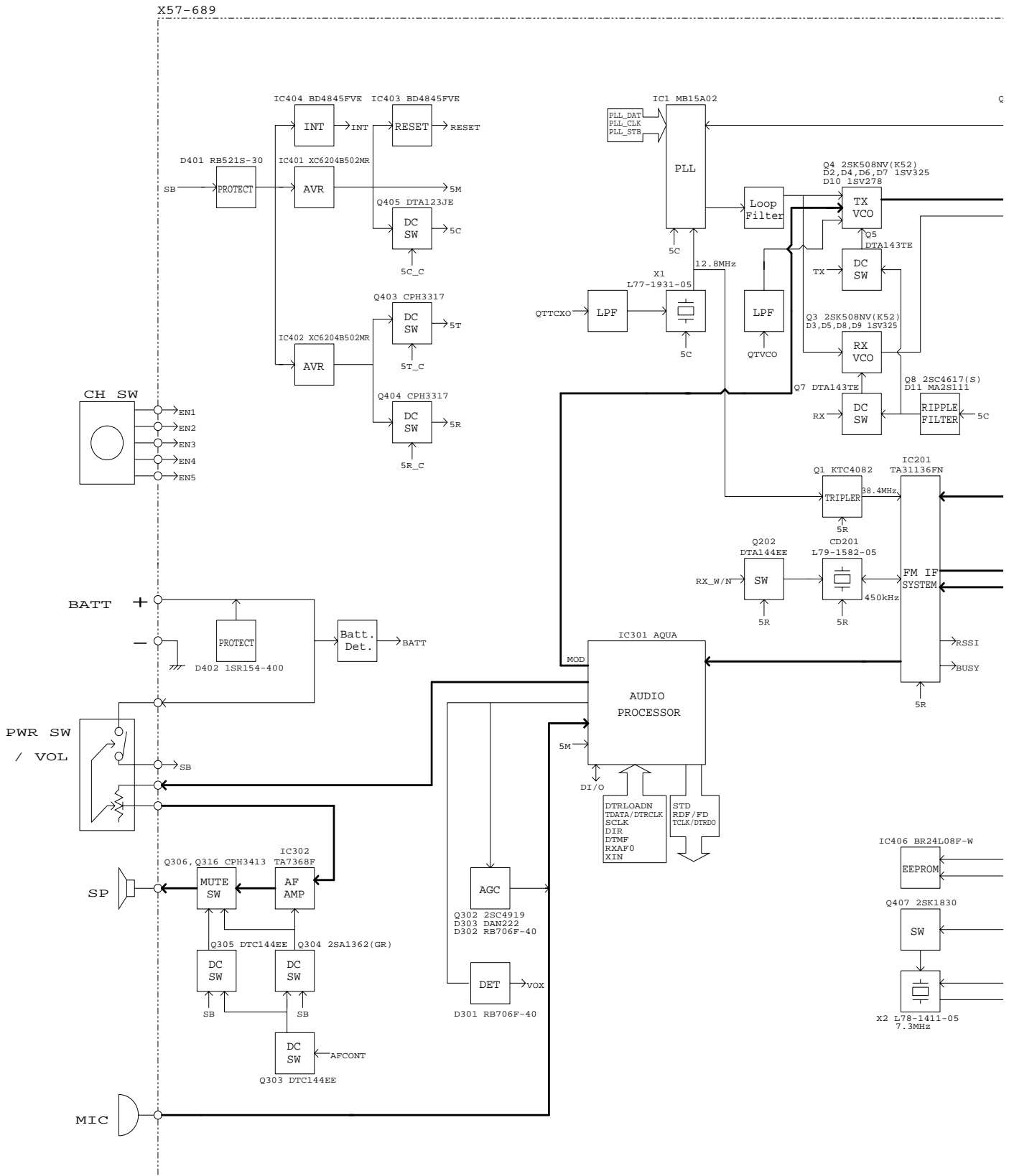

BLOCK DIAGRAM

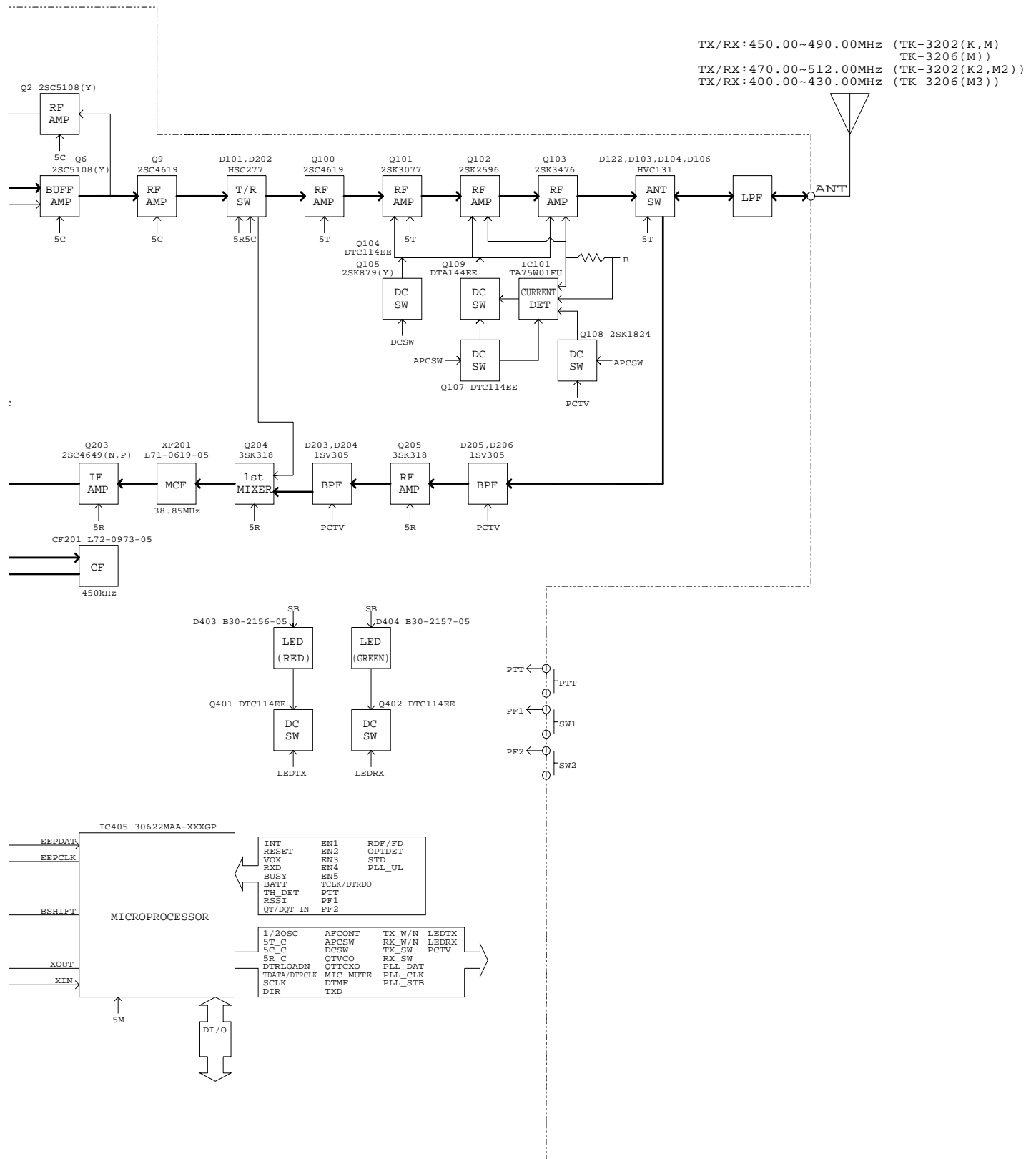

LEVEL DIAGRAM

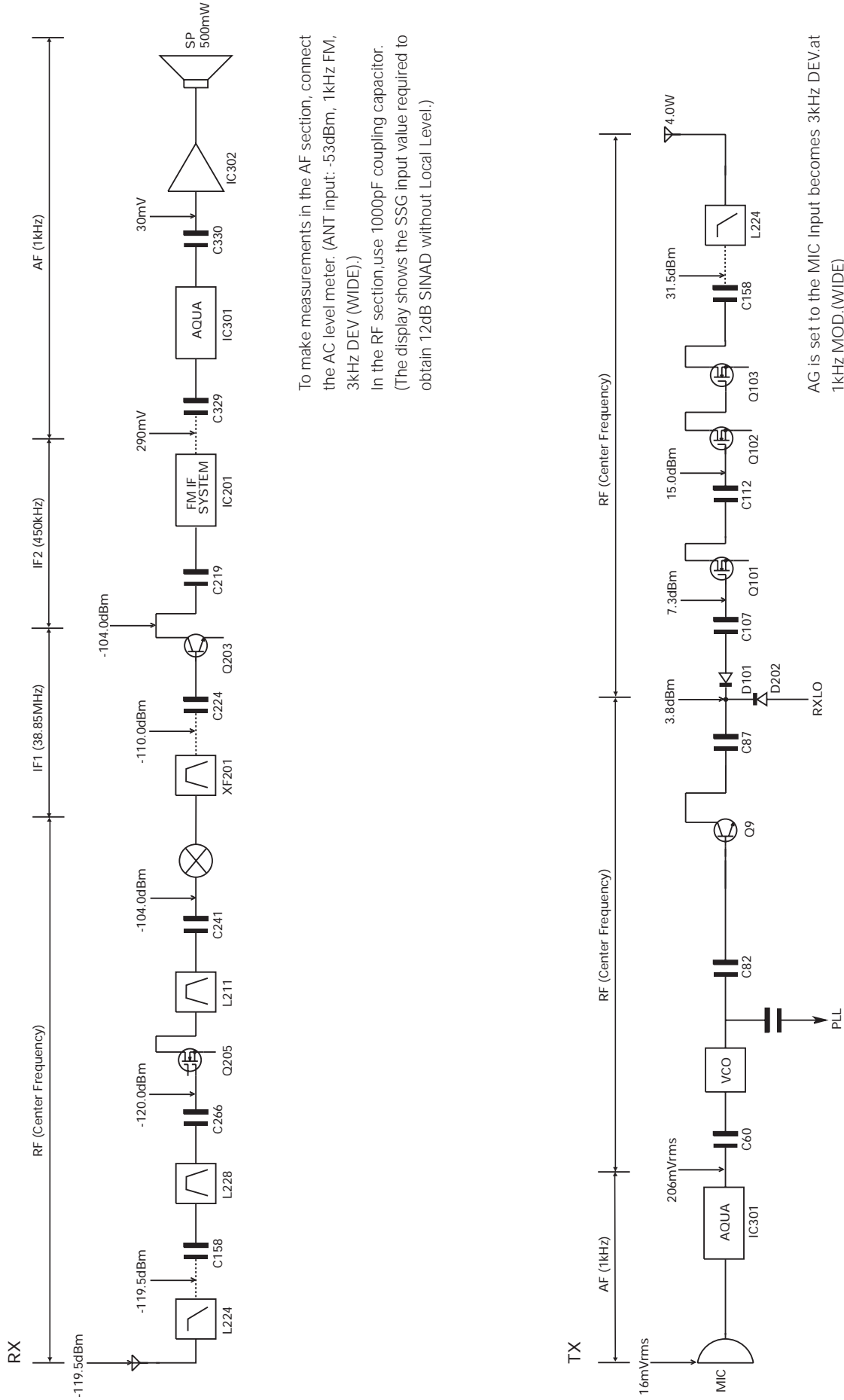

To make measurements in the AF section, connect the AC level meter. (ANT input: -53dBm, 1kHz FM, 3kHz DEV (WIDE).)

In the RF section, use 1000pF coupling capacitor. (The display shows the SSG input value required to obtain 12dB SINAD without Local Level.)

AG is set to the MIC Input becomes 3kHz DEV at 1kHz MOD. (WIDE)

To make measurements in the AF section, connect the AC level meter.

In the RF section, use 1000pF coupling capacitor.

TK-3202/3206

SPECIFICATIONS

General

Frequency Range	450~490MHz (TK-3202(K,M) TK-3206(M)) 470~512MHz (TK-3202(K2,M2)) 400~430MHz (TK-3206(M3))
Number of channels	Max. 8 (TK-3202) Max. 16 (TK-3206)
Number of groups	Max. 16
Channel Spacing	25kHz (Wide) 12.5kHz (Narrow)
PLL Channel Stepping	5kHz, 6.25kHz
Operating Voltage	7.5 V DC \pm 20%
Battery Life	More than 14 hours at 4 watts (5-5-90 duty cycle with KNB-29N battery) More than 9 hours at 4 watts (5-5-90 duty cycle with KNB-30A battery)
Operating Temperature range	-30°C to +60°C (-22 °F to +140 °F)
Frequency Stability	\pm 2.5ppm (-30°C to +60°C)
Channel Frequency Spread	40MHz (TK-3202(K,M) TK-3206(M)) 42MHz (TK-3202(K2,M2)) 30MHz (TK-3206(M3))
Dimensions and Weight	
Radio Only	54 (2-1/8) W x 122 (4-13/16) H x 21.1 (13/16) D mm (inches) 160g (0.35lbs)
With KNB-29N (1500mAh battery)	54 (2-1/8) W x 122 (4-13/16) H x 33 (1-5/16) D mm (inches) 360g (0.79lbs)
With KNB-30A (1100mAh battery)	54 (2-1/8) W x 122 (4-13/16) H x 33 (1-5/16) D mm (inches) (Dimensions not including protrusions) 340g (0.75lbs)

Receiver (Measurements made per TIA/EIA-603)

Sensitivity	
EIA 12dB SINAD	0.25 μ V (Wide)/0.28 μ V (Narrow)
Selectivity	70dB (Wide)/60dB (Narrow)
Intermodulation	65dB (Wide)/60dB (Narrow)
Spurious response	60dB
Audio Power Output	500mW at 8 Ω less than 10% distortion

Transmitter (Measurements made per TIA/EIA-603)

RF Power Output	4W/1W
Spurious and Harmonics	65dB
Modulation	16K ϕ F3E (Wide)/11K ϕ F3E (Narrow)
FM Noise	45dB (Wide)/40dB (Narrow)
Audio Distortion	Less than 5%

KENWOOD CORPORATION

2967-3, Ishikawa-machi, Hachioji-shi, Tokyo 192-8525, Japan

KENWOOD U.S.A. CORPORATION

P.O. BOX 22745, 2201 East Dominguez Street, Long Beach, CA 90801-5745, U.S.A.

KENWOOD ELECTRONICS CANADA INC.

6070 Kestrel Road, Mississauga, Ontario, Canada L5T 1S8

KENWOOD ELECTRONICS DEUTSCHLAND GMBH

Rembrücker Str. 15, 63150 Heusenstamm, Germany

KENWOOD ELECTRONICS BELGIUM N.V.

Leuvensesteenweg 248 J, 1800 Vilvoorde, Belgium

KENWOOD ELECTRONICS FRANCE S.A.

13, Boulevard Ney, 75018 Paris, France

KENWOOD ELECTRONICS U.K. LIMITED

KENWOOD House, Dwight Road, Watford, Herts., WD18 9EB, United Kingdom

KENWOOD ELECTRONICS EUROPE B.V.

Amsterdamseweg 37, 1422 AC Uithoorn, The Netherlands

KENWOOD ELECTRONICS ITALIA S.p.A.

Via G. Sirtori, 7/9 20129 Milano, Italy

KENWOOD IBERICA S.A.

Bolivia, 239-08020 Barcelona, Spain

KENWOOD ELECTRONICS AUSTRALIA PTY. LTD.

(A.C.N. 001 499 074)

16 Giffnock Avenue, Centrecourt Estate, North Ryde, N.S.W. 2113, Australia

KENWOOD ELECTRONICS (HONG KONG) LTD.

Unit 3712-3724, Level 37, Tower one Metroplaza, 223 Hing Fong Road, Kwai Fong, N.T., Hong Kong

KENWOOD ELECTRONICS SINGAPORE PTE LTD.

1 Genting Lane #07-00 Kenwood Building, Singapore 349544

